

Understanding And Operating The 8555A Spectrum Analyzer And 8445B Preselector

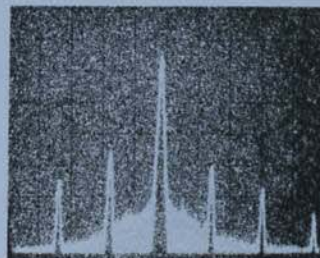
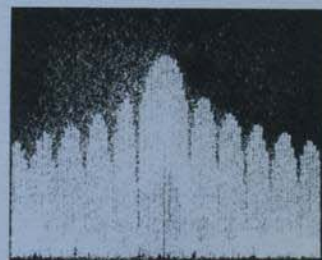
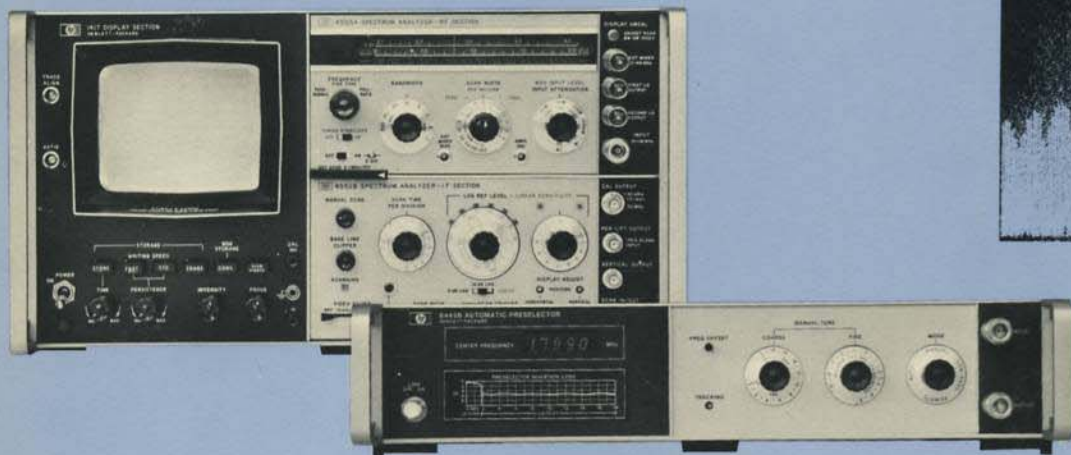
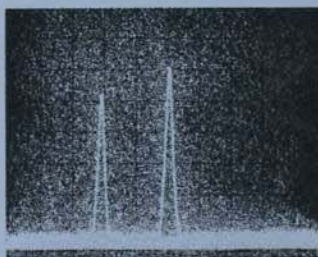
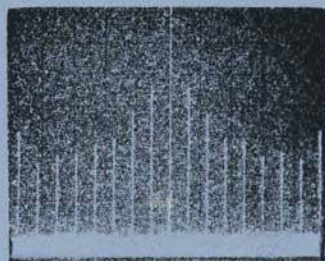

APPLICATION NOTE 136

**Understanding and Operating
the 8555A Spectrum Analyzer
and 8445B Preselector**

Printed SEPTEMBER 1973

HEWLETT  PACKARD

CONTENTS

	Page
CHAPTER 1. Understanding Spectrum Analysis	1
CHAPTER 2. Interpreting the Display in a Harmonic Mixing Analyzer	3
CHAPTER 3. Controls, Indicators, and Connectors	13
CHAPTER 4. Front Panel Adjustments	21
CHAPTER 5. Operating the Spectrum Analyzer	25
APPENDIX I. Theory of Operation	36

CHAPTER 1

UNDERSTANDING SPECTRUM ANALYSIS

The key to spectrum analysis is the measuring instrument itself. Once the instrument is understood, measurement set-up and applications are far easier to master. The required instrument expertise is in the area of turning front panel controls to get the desired image on the CRT and then interpreting the results. In a harmonic mixing analyzer it is necessary to more carefully scrutinize the image on the CRT to interpret the results. With this in mind we have structured this note around the instrument itself, rather than the measurement set-up or applications. For further applications information please see any of the following:

1. Spectrum Analyzers for Design Engineers, No. 5952-0932
2. AN 63E, Modern EMI Measurements
3. AN 142, EMI Measurement Procedure
4. AN 150, Basic Spectrum Analysis
5. AN 150-1, Amplitude and Frequency Modulation
6. AN 150-2, Pulsed RF
7. AN 150-3, Tracking Generators
8. AN 150-4, Noise Measurements
9. AN 150-5, CRT Photography and Recording

To better understand the references in the later chapters, all chapters in this note should be read in sequence. To explain this point further, the second chapter provides a theoretical foundation for the operation of a spectrum analyzer. The following chapters build on that foundation. These chapters discuss first front panel controls, then adjustments, and finally culminate in a live demonstration. The theory of operation, although an appendix, is recommended reading.

Before we launch into the next chapter, let us briefly describe the product we will be discussing. The spectrum analyzer system consists of four possible components:



8445B: The 8445B Preselector, a tracking band-pass filter, is a recommended component in every 8555A Microwave Spectrum Analyzer System. The 8445B Preselector is a tracking filter from 1.8 to 18 GHz and a low pass filter from 10 MHz to 1.8 GHz. Option 004 deletes the low pass filter. The tracking filter eliminates image, multiple, and spurious responses. The spurious responses eliminated are harmonic distortion products and intermodulation distortion products. By eliminating these spurious responses, the DYNAMIC RANGE

of the spectrum analyzer is enhanced. The low pass filter eliminates image and multiple responses only. A description of how a preselector eliminates unwanted responses is contained in Chapter 2. The preselector also prevents LO power from emanating out the input port of the analyzer. The operation of the 8445B Preselector is **completely automatic** with the 8555A system. This leaves the operator free to concentrate on the measurement itself.

140T or 141T: The user has a selection of mainframe—either the 140T or the variable persistence 141T. Many of you are aware of the advantages of variable persistence. Since the 8555A analyzer with 100 Hz bandwidth requires slower scans than previous microwave analyzers, variable persistence is more advantageous than ever before.

8555A: The RF Section is the 8555A. It covers the frequency range of 10 MHz to 18 GHz with coaxial input and 12.4 to 40 GHz with an external waveguide mixer.



8552A or 8552B: Two IF Sections are available—the 8552A and the high resolution 8552B. The 8552B has all the advantages of the 8552A and in addition incorporates the following features:

- Higher resolution
- 11:1 IF filter shape factors (60 dB/3 dB bandwidth)
- 2 dB/DIV log expand scale
- Manual scan
- 10 Hz video filter

The advantages of these features will be demonstrated later. The 8552B is the **best IF Section** for **any** spectrum analyzer including the 8555A system.

CHAPTER 2

INTERPRETING THE DISPLAY IN A HARMONIC MIXING ANALYZER

INTRODUCTION

The 8555A along with the 8551B is a harmonic mixing spectrum analyzer. Harmonic mixing allows broad frequency coverage for spectrum analyzers but requires careful interpretation of the CRT. In order to interpret the spectrum analyzer display, it is important to understand multiple and image responses, how they can be identified, and then eliminated along with other unwanted responses. This chapter will briefly review the aspects of harmonic mixing that you should be familiar with. Harmonic mixing is a subject that is easily understood once a few basic concepts are grasped.

TUNING EQUATION

The simplified block diagram of the 8555A Spectrum Analyzer is shown below (Figure 1). Note that it resembles a superheterodyne radio receiver. The analyzer and a receiver contain much the same elements. The input signal frequencies that will pass through the IF of the analyzer can be described as the following:

$$\left| F_{\text{input signal}} - F_{\text{lo}} \right| = F_{\text{if}}$$

Putting this in a slightly different form yields:

$$F_{\text{input signal}} = F_{\text{lo}} \pm F_{\text{if}}$$

Letting $F_{\text{input signal}} = F_s$

$$F_s = F_{\text{lo}} \pm F_{\text{if}}$$

Depending on whether the plus or minus sign is used, we will have a different solution to the equation. To identify these solutions, let us define the "+" (plus) mode of mixing to refer to the solution of the equation using the positive sign. The "-" (minus) mode of mixing can be defined in the same manner.

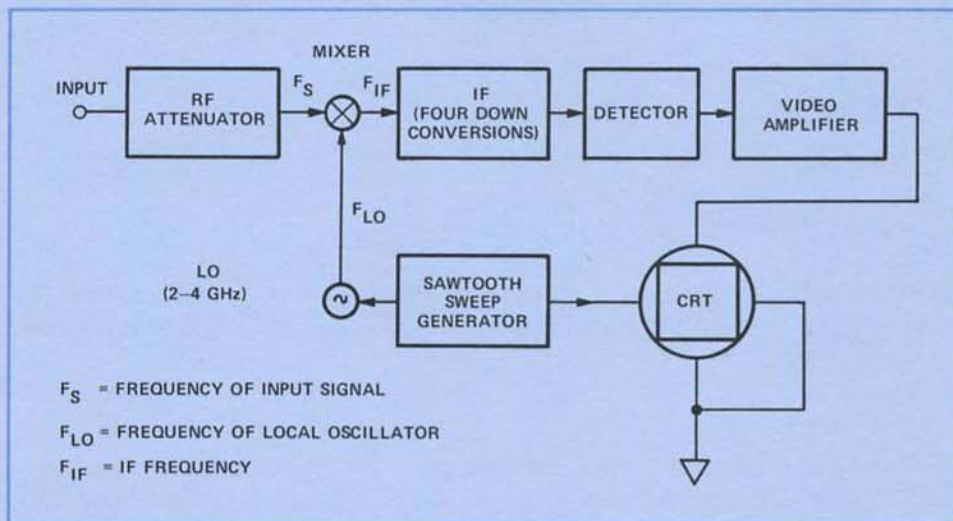

Figure 1. Simplified Block Diagram of Spectrum Analyzer.

HARMONIC MIXING

The frequency range of the spectrum analyzer where $F_{if} = 2.05$ GHz and when F_{lo} goes from 2.05 to 4.10 GHz can be calculated in the following manner (2.05 will be rounded to 2 and 4.10 to 4):

First for the “-” mixing mode

$$\begin{aligned}F_s &= F_{lo} - F_{if} \\ &= 2 - 2 = 0 \text{ GHz} \\ &= 4 - 2 = 2 \text{ GHz}\end{aligned}$$

Therefore, the analyzer range is 0-2 GHz in the minus mixing mode. In the case of the 8555A, 0 is not actually achievable because of an input dc blocking capacitor which protects the input mixer.

Then for the “+” mixing mode

$$\begin{aligned}F_s &\pm F_{lo} + F_{if} \\ &= 2 + 2 = 4 \text{ GHz} \\ &= 2 + 4 = 6 \text{ GHz}\end{aligned}$$

Therefore, the analyzer range is 4-6 GHz in the plus mixing mode.

Summarizing the mixing mode frequency ranges—they are 0-2 GHz and 4-6 GHz. This analyzer is very limited in its frequency range. One method for increasing the frequency range of the analyzer is to increase the frequency range of the local oscillator. One way to do this is to use harmonics of the local oscillator in mixing. The generalized tuning equation then becomes:

$$F_s = nF_{lo} \pm F_{if}$$

where n = mixing harmonic of the LO

In the 8555A, calibrated frequency measurements can be made for the following values of n : 1, 2, 3, 4, 6, and 10. Let us use the tuning equation to calculate the frequency range of such a harmonic mixing analyzer. To solve for the low frequency limit, let $n = 1$ and the mixing mode be minus:

$$\begin{aligned}F_s &= nF_{lo} - F_{if} \\ F_s &= 1 \times 2 = 0 \text{ GHz}\end{aligned}$$

To solve for the high frequency limit, let $n = 10$ and the mixing mode be plus:

$$\begin{aligned}F_s &= nF_{lo} + F_{if} \\ F_s &= 10 \times 4 + 2 = 42 \text{ GHz}\end{aligned}$$

The lower and upper limits of the frequency range are now 0-42 GHz. Thus, by using harmonic mixing, the frequency range of the spectrum analyzer has been extended.

TUNING CURVES

Plotting the generalized tuning equation ($F_s = nF_{lo} \pm F_{if}$) will lead to a better understanding of image and multiple responses. F_s will be the dependent variable and F_{lo} the independent variable. F_{if} is fixed at 2 GHz for the 8555A. First, let us plot the tuning equation for the case $n = 1$ (Figure 2).

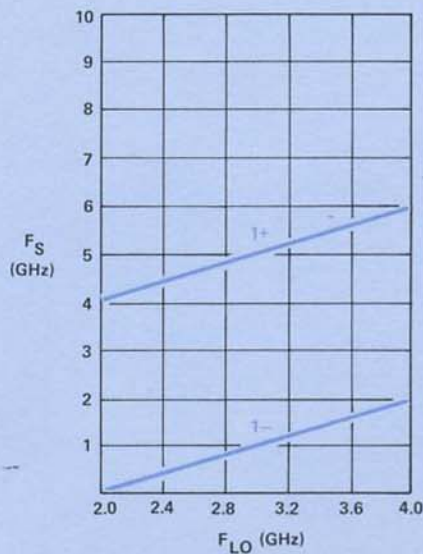

Figure 2. Plot of $F_s = F_{10} \pm 2$ GHz.

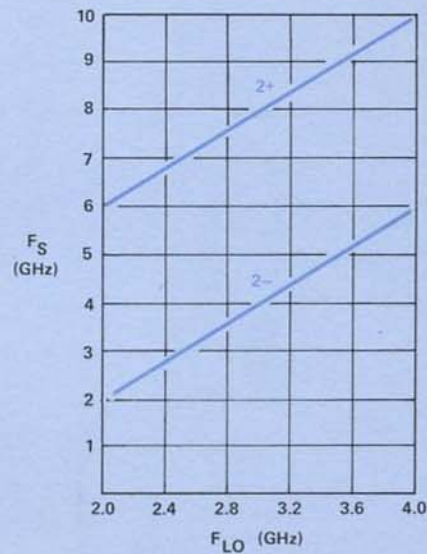

Figure 3. Plot of $F_s = 2 \times F_{10} \pm 2$ GHz.

Note the frequency range of this analyzer is 0-2 GHz and 4-6 GHz. Figures 3 and 4 represent plots of the tuning equation for the case $n = 2$ and $n = 3$. Note the increase in frequency range of the spectrum analyzer through the use of harmonic mixing. Placing all the curves on one chart, as in Figure 5, yields a graph of the composite tuning curves. For a more detailed diagram of the composite tuning curves for the 8555A, see Figure 21 at the end of this chapter.

IMAGE RESPONSES

The two responses of the analyzer ("+" and "-" mixing mode) in Figure 2 are called an image pair for fundamental mixing. Figures 3 and 4 demonstrate image pairs for the case $n = 2$ and $n = 3$. Note that image pairs are always separated by twice the IF frequency.

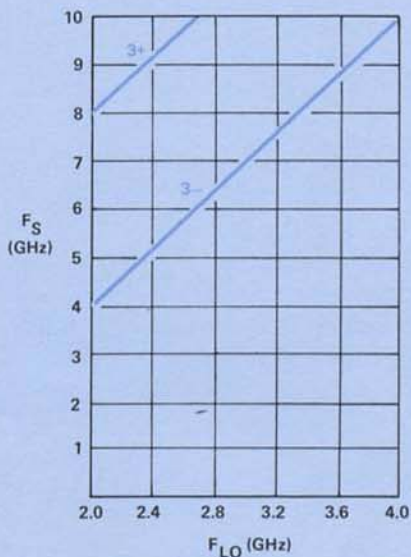

Figure 4. Plot of $F_s = 3 F_{10} \pm 2$ GHz.

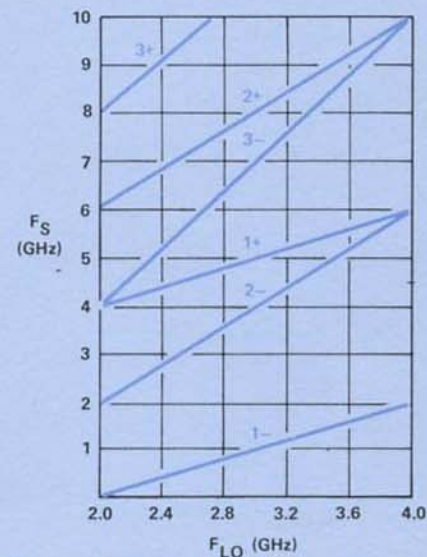

Figure 5. Composite Tuning Curves.

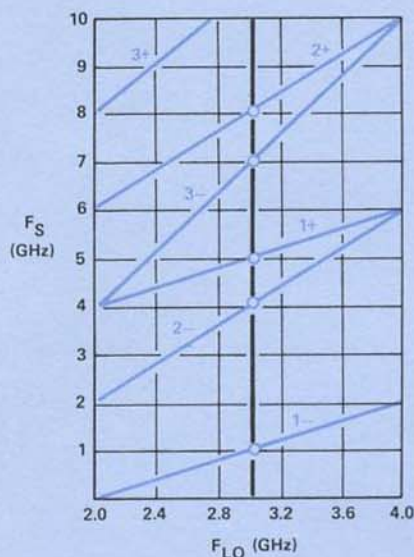

Figure 6. Image Responses at a LO frequency of 3 GHz.

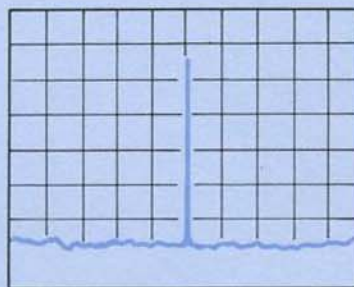

Figure 7. Image Responses on a display of a Spectrum Analyzer.

Image pairs make it possible for signals of several different frequencies to all enter simultaneously and appear as one signal on the CRT. Let us use the composite tuning curves to see how this is possible. Assume that the frequency of the first LO is fixed at 3 GHz. Figure 6 indicates the number of possible responses of the analyzer to an input signal for this fixed LO frequency. These responses are image responses. The horizontal axis of the CRT in the analyzer corresponds to a LO sweep of 2 - 4 GHz. Hence, the horizontal axis on the CRT corresponds to the horizontal axis of the graph in Figure 6. This implies that a LO frequency of 3 GHz translates to one and only one specific point on the CRT. What this means in terms of display is that one vertical line in the CRT could actually be several lines superimposed on each other. See Figure 7.

We have been discussing a very specialized case by fixing the LO at a frequency of 3 GHz. Let us sweep the LO from 2 to 4 GHz and generalize the concept of images. Assume that we are interested in looking at a 1 GHz input signal. The desired response is a 1 GHz signal on the 1- mode in Figure 8.

Assume also that input signals of 3.5 GHz, 4.5 GHz, 5.2 GHz, and 8.8 GHz are also present. The responses of the analyzer in Figure 8 are image responses. By comparing Figures 6 and 8, we see that images do not necessarily have to all appear at the same LO frequency. Figure 9 shows the images of Figure 8 as they might appear on the face of the CRT in the spectrum analyzer. **Simultaneous** viewing of images is not desirable since horizontal frequency scale calibration is different for each half of the pair; i.e., the horizontal axis corresponds to 0 - 2 GHz for the 1- mode and 4 - 6 GHz for 1+ mode. We want to view the 1 GHz signal of interest without any other image present.

Unwanted images can be eliminated through the use of passive filters. To see how this is possible, consider the following example. Let us apply the five input signals to the spectrum analyzer that we considered in Figure 8; but this time we will place a bandpass filter (0 - 2 GHz) at the input of the analyzer. The shaded area

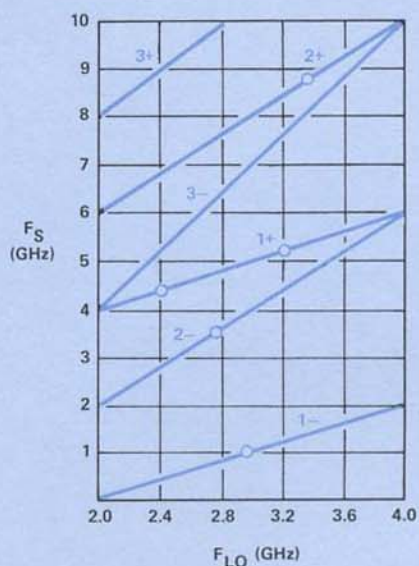

Figure 8. Image Responses of Spectrum Analyzer for input signals of 1 GHz, 3.5 GHz, 4.5 GHz, 5.2 GHz, and 8.8 GHz.

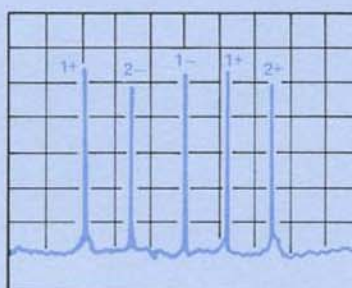

Figure 9. Image Responses of Spectrum Analyzer for input signals of 1 GHz, 3.5 GHz, 4.5 GHz, 5.2 GHz, and 8.8 GHz. (Multiple responses not included in illustration.)

in Figure 10 indicates the rejection band of the filter. Note that the unwanted image responses are rejected. Figure 11 demonstrates the corresponding CRT image. The bandpass filter, however, is only partially effective in eliminating images. This is due to the fact that it does not have an infinitely narrow bandpass. It is possible, therefore, for an image-causing signal, close in frequency to the desired signal, to pass through the input bandpass filter. Images only occur, of course, if input signals of the frequencies that produce images are in fact applied to the input of the analyzer.

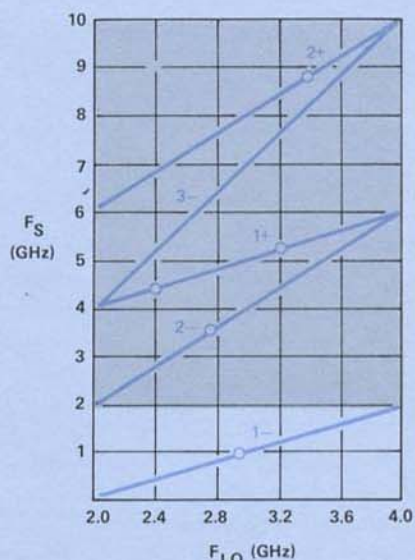

Figure 10. Rejection of Image Responses with bandpass filter.

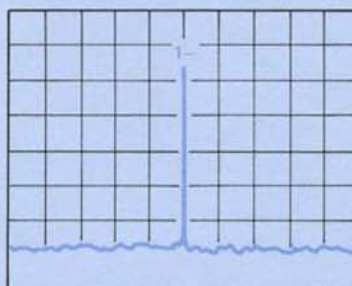

Figure 11. Image-free display of Spectrum Analyzer with 1 GHz input signal.

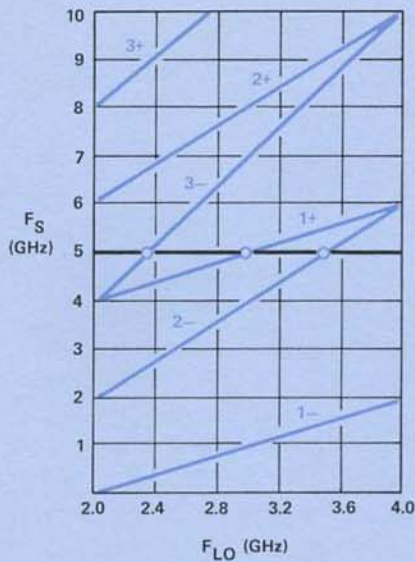

Figure 12. Multiple Responses for 5 GHz input signal.

MULTIPLE RESPONSES

It is possible for one input signal to a spectrum analyzer to appear as three separate signals on the CRT. To see how this occurs, let us fix the input signal frequency F_s at 5 GHz and vary the LO frequency F_{LO} over its full range 2 - 4 GHz. Figure 12 demonstrates the responses that occur in the display. These responses are called multiple responses.

Multiple responses occur at different LO frequencies. Remember that a particular LO frequency corresponds to a particular horizontal position on the CRT. Hence, multiple responses occur at different horizontal positions on the CRT. See Figure 13.

Because of the possibility of multiple as well as image responses, all harmonic mixing analyzers adopt some scheme for signal identification. Signal identification allows the selection of appropriate frequency band scale and determination of signal frequency. The scheme on the 8555A is very easy to use. The signal of interest is brought to near-center screen and the scan width is narrowed to any setting 1 MHz/division or less. Signal identification is easier if the scan width is narrowed until the signal of interest is the only signal on the screen. See Figure 14.

The signal identifier is turned on. If the display on the CRT resembles the one engraved on the front panel of the 8555A, then positive signal identification is made as in Figure 15. The frequency of the signal can then be read off the frequency band scale. If positive signal identification does not occur on the initial try, the frequency band scale is advanced until positive identification does occur. Signal identification is **not** necessary, however, if multiple responses can be eliminated.

Fixed passive bandpass filters will **not** eliminate multiple responses as shown in Figure 16. Note that multiple responses still exist for 5 GHz input signal even with a 4 - 6 GHz bandpass filter. However, a tracking narrow bandpass filter will eliminate such responses. Such a filter is called a preselector. Since the preselector is a tracking filter, it can be made to track a particular tuning curve the user selects. In Figure 17, the preselector is tracking the 1+ mode of the analyzer. With a pre-

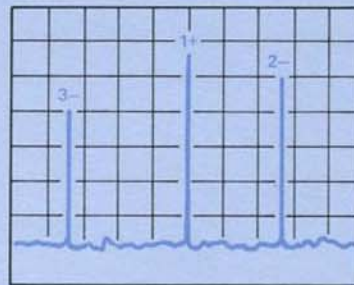

Figure 13. Multiple Responses of 5 GHz input signal on display of 8555A Spectrum Analyzer.

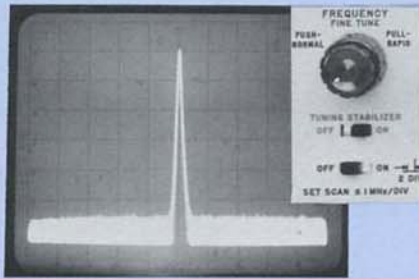

Figure 14. Signal Identifier OFF. Signal of Interest in near-center screen. Scan width ≤ 1 MHz/division.

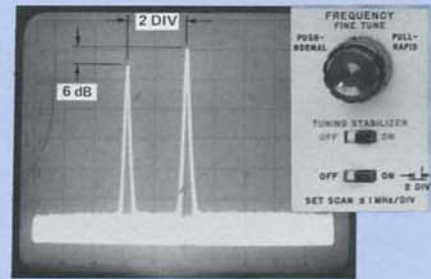

Figure 15. Signal Identifier ON. Signal of Interest is identified positively. Frequency of signal can be read directly off frequency band scale.

selector the multiple responses are rejected. Note also that a preselector will reject image as well as multiple responses.

Just how does the preselector reject multiple responses? Let's consider Figure 17 again. The operation of a preselector is a matter of timing. Let us consider the time interval during which the LO scans from 2 to 4 GHz. A 5 GHz input signal is applied. The preselector tuning is determined by the desired spectrum analyzer tuning equation. In this case, let us pick the following:

$$\begin{aligned}
 F_s &= nF_{10} \pm F_{if} \\
 &= (+1) F_{10} + 2 \\
 &\text{(in GHz)}
 \end{aligned}$$

Since the starting point is a LO frequency of 2 GHz, the preselector is tuned to 4 GHz and is rejecting the input signal. The LO now begins its scan. When the LO is at 2.35 GHz, the point where the first multiple response occurs, the preselector

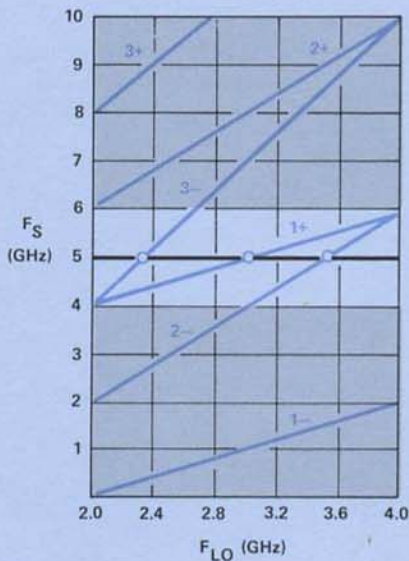

Figure 16. Multiple Responses for a 5 GHz input signal are not eliminated with a passive fixed 4-6 GHz Bandpass Filter.

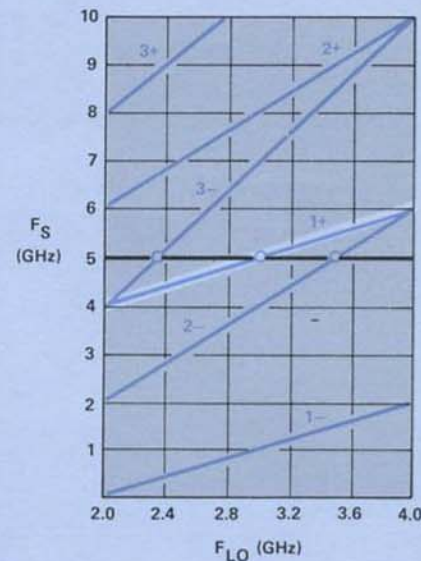

Figure 17. Image as well as Multiple Responses are rejected for any input signal with a Preselector (Tracking Input Filter).

is tuned to 4.35 GHz. The bandpass of the preselector is narrow, approximately 0.05 GHz. Hence, the input signal at 5 GHz is rejected and doesn't get into the analyzer and there is no multiple response in the display. When the LO is at 3 GHz, the preselector is tuned to 5 GHz, allowing the input signal to pass. This is the desired response of the analyzer. When the LO is at 3.5 GHz, the point at which another multiple occurs, the preselector is tuned to 5.5 GHz and no multiple occurs. In this way, only the desired response passes through to the input mixer of the spectrum analyzer.

Signal identification is **NOT** necessary when a preselector is used, since no multiple or image responses exist on the display of the analyzer.

The 8445B Preselector in the standard version is equipped with a low pass filter. The reason for this is that the tracking filter will not function below 1.8 GHz, since the filter element, a YIG sphere, will not resonate below 1.8 GHz. This is not a serious limitation, however. Consider the following: Let's place a 0-1.8 GHz low pass filter on the input of the spectrum analyzer. Note in Figure 15 only the 1- mode curve is in this range. Therefore, no multiple responses are possible. The low pass filter removes the image responses also. Hence, for **ONLY** the 1- mixing mode, the use of a simple fixed passive filter will result in the elimination of both multiple and image responses. By use of such a filter, then, the frequency range of multiple and image-free operation is extended down from 1.8 GHz to 10 MHz—the low frequency limit of the spectrum analyzer. The 8445B Preselector offers a low pass fixed filter built into the preselector package in the standard model. Option 004 will remove the low pass filter to reduce the price of the 8445B Preselector for anyone who does not use the analyzer below 1.8 GHz.

SPURIOUS RESPONSES

If an input signal is of sufficient amplitude, the input mixer can be driven into nonlinear operation. When this occurs, harmonics of the input signal are generated. These are called spurious responses. It is also possible for two input signals of strong amplitude to drive the input mixer into nonlinear operation and, therefore, intermodulate. This intermodulation results in the generation of distortion products. These distortion products are also called spurious responses. Therefore, spurious responses are generally of two types:

1. Harmonics of input signal.
2. Intermodulation products of two input signals.

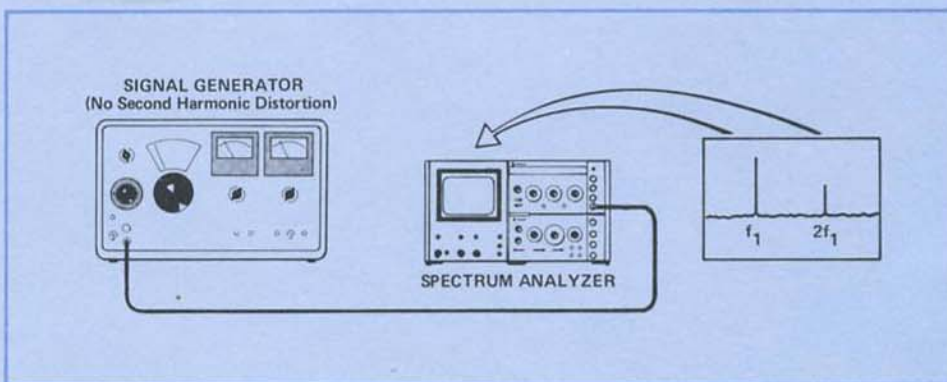

Figure 18. Input Signal of large amplitude driving input mixer into nonlinear operation, resulting in the generation of second harmonic distortion products.

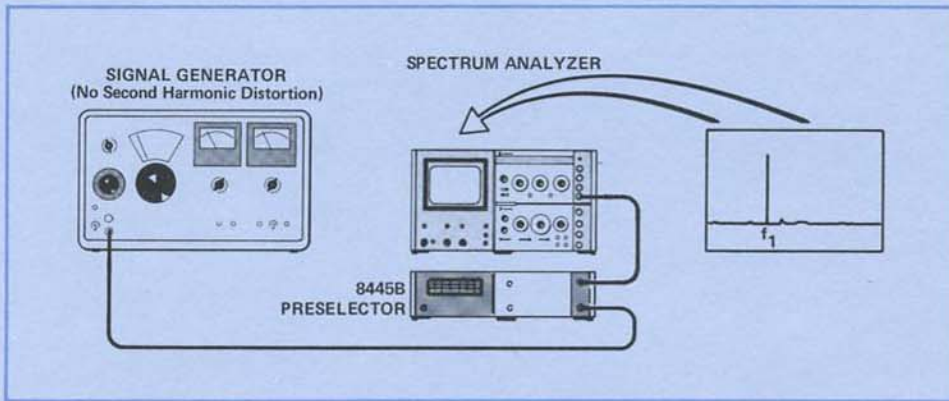

Figure 19. A Preselector (Tracking Input Filter) reduces distortion products caused by input signals of large amplitude.

How do we eliminate spurious responses? In addition to eliminating images and multiple responses, a tracking filter (1.8 - 18 GHz) will also virtually eliminate spurious responses. Consider the example in Figure 18. A large amplitude signal is driving the input mixer into nonlinear operation, resulting in a display of f_1 and $2f_1$ with **only** f_1 present at the input.

What happens when a preselector is inserted? Let's follow the scan of the LO in the spectrum analyzer. The LO starts at 2 GHz. This corresponds to the left edge of the CRT. The LO begins to scan. When the LO reaches the appropriate frequency to convert f_1 to the IF of the analyzer, the preselector is also tuned to f_1 . Hence, the signal at frequency f_1 enters the analyzer and appears on the CRT. When the LO reaches a frequency to allow $2f_1$ to enter the IF of the analyzer, the preselector is also tuned to $2f_1$. But the input signal is at a frequency of f_1 . It is rejected and, therefore, cannot enter the analyzer and overdrive the input mixer. (See Figure 19.) No harmonic appears on the CRT face. In this way spurious responses are eliminated. Intermodulation products are eliminated in a similar fashion provided the intermodulating signals are separated by 40 MHz, the bandwidth of the preselector. Figures 20A and 20B demonstrate the difference a preselector can make. By reducing spurious responses, the 8445B Preselector increases the dynamic range of the 8555A Spectrum Analyzer.

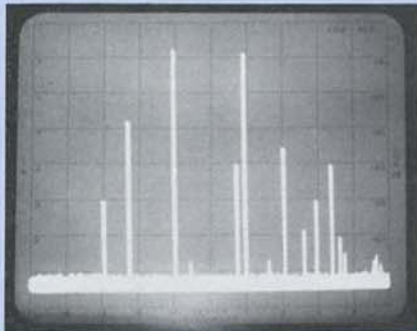

Figure 20A. Spectrum Analyzer display of two large amplitude signals. Log Ref: -10 dBm. Scan width: 50 MHz/div. Center frequency: 3.5 GHz.

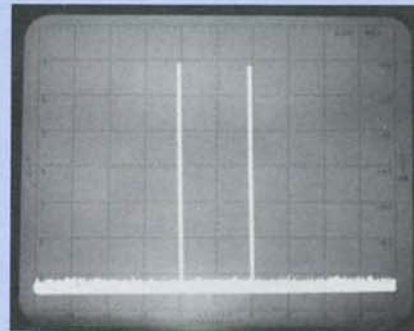

Figure 20B. Spectrum Analyzer display of two large signals after Pre-selector added. Log Ref: -10 dBm. Scan width: 50 MHz/div. Center frequency: 3.5 GHz.

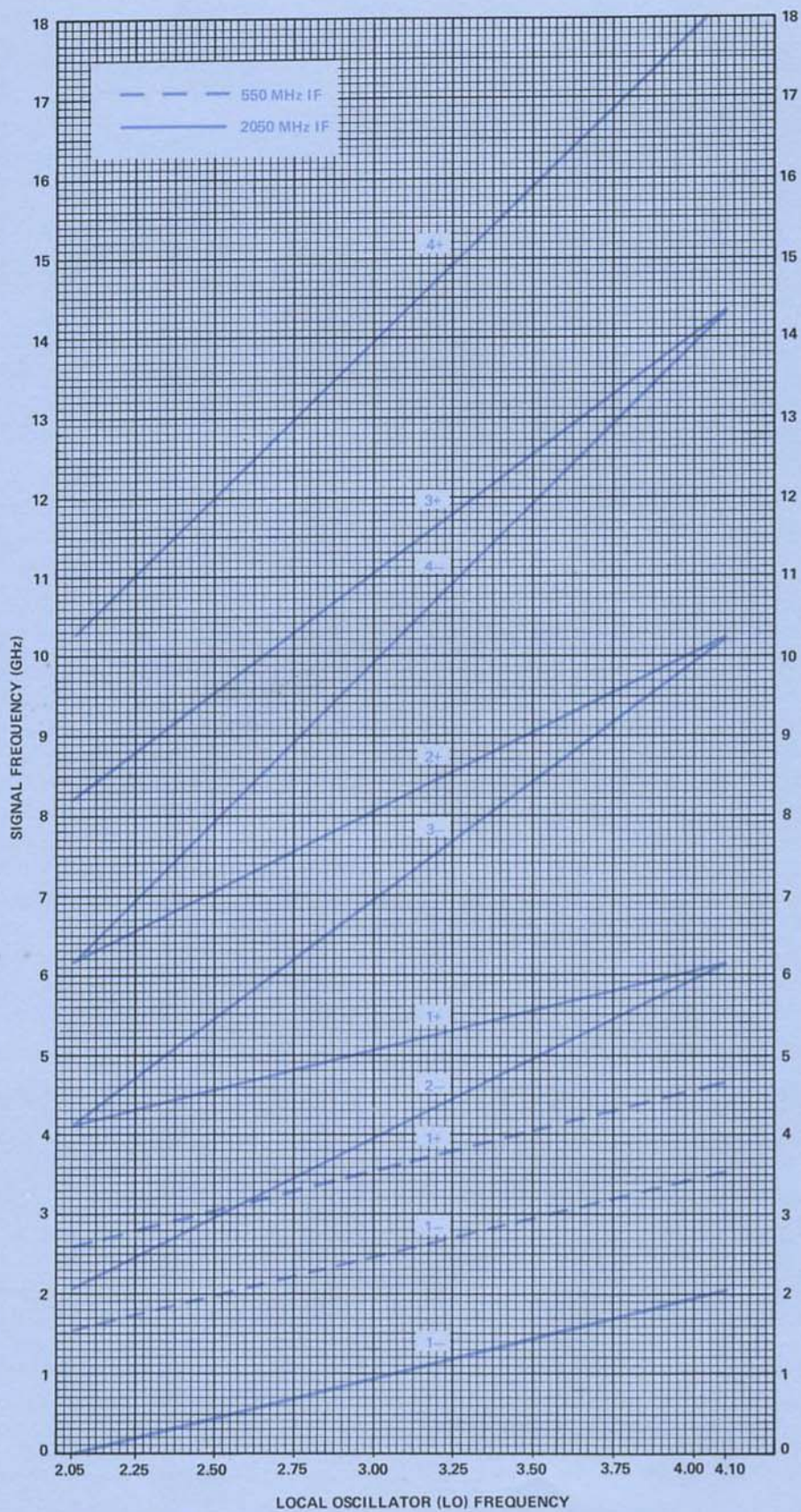

Figure 21. Composite Tuning Curves for 8555A with internal mixing.

CHAPTER 3

CONTROLS, INDICATORS, AND CONNECTORS

This section provides a description of all operating controls, indicators, and connectors. The information given is intended as a capsule summary only. More detailed description of the control functions can be found in Appendix I.

The 8555A can be configured with one of two IF sections, the 8552A and 8552B; one of two mainframes, the 140T and 141T; and with or without an 8445B Preselector. The particular combination described is the 8555A/8552B/141T/8445B Option 002. This system was chosen since all of the controls on the 8552A are also on the 8552B; all of the controls on the 140T are on the 141T; and all of the controls on the 8445B are also in the Option 002 model. The numbered control descriptions below are keyed to the photo of the 8555A system (Figure 22). **FOLD PAGE 19 OUT SO IT CAN BE SEEN WHILE READING THE CONTROL DESCRIPTIONS.**

1. **ASTIGMATISM:** Controls CRT spot shape. Adjust with FOCUS (38) to obtain sharpest definition of travel over entire CRT Display.
2. **TRACE ALIGN:** Adjust to make baseline of trace parallel to horizontal graticule line.
3. **CRT DISPLAY AND GRATICULE:**
 - a) Linear (voltage) amplitude calibration scale. Use when selector switch (29) is set to LINEAR.
 - b) Logarithmic (power) amplitude calibration scale. Use when selector switch (29) is set to 10 dB or 2 dB LOG. Scale calibration (10 dB/DIV or 2 dB/DIV) is referred to LOG REF graticule (3C).
 - c) Absolute power level reference (dBm) for LOG display. Absolute power level of LOG REF established by settings of INPUT ATTENUATION (15) and LOG REF LEVEL (27) controls.
 - d) Display center frequency determined by FREQUENCY (5) and FINE TUNE (6) controls; center frequency indicated on FREQUENCY BAND SCALE (10).
 - e) Frequency relative to center frequency.
4. **SIGNAL IDENTIFIER:** Use to choose appropriate FREQUENCY BAND SCALE (10). To use SIGNAL IDENTIFIER, SCAN WIDTH PER DIVISION (12) must be 1 MHz/DIV or less. Turn SIGNAL IDENTIFIER ON. Change FREQUENCY BAND SCALE (10) until display on CRT will resemble the one engraved on the front panel near the SIGNAL IDENTIFIER switch; i.e., two signals will appear spread exactly 2 DIV apart and the one on the left will be slightly less in amplitude. Read frequency of signal under cursor on FREQUENCY BAND SCALE (10).

Note:

The 8555A does not offer frequency scales for the $n = 5, 7, 8,$ and 9 mixing modes. The input signal frequency range corresponding to these mixing modes is covered adequately by the $n = 3, 4, 6,$ and 10 mixing modes. Use the $n = 3, 4, 6,$ and 10 mixing modes to view the signal of interest. However, to identify a signal on modes $n = 5, 7, 8,$ and $9,$ use the following procedure:

When a signal cannot be positively identified on any of the 8555A frequency band scales, choose a scale where the signal shifts to the **Left** and calculate the mixing mode using the following formula:

$$n = \frac{2 \text{ DIV}}{\text{signal shift}} \times (\text{n of FREQUENCY BAND SCALE selected})$$

where n = actual mixing mode, signal shift = signal shift to the **Left** on CRT in DIV with SIGNAL IDENTIFIER ON.

Then use the tuning equation $F_s = nF_{10} \pm F_{IF}$ to calculate F_s , the input signal where n = mixing mode, F_{10} = Local Oscillator frequency, and F_{IF} = IF freq. Read F_{10} off the FREQUENCY BAND SCALE. The "+" or "-" sign is determined by the polarity of the mixing mode on the FREQUENCY BAND SCALE also.

This calculation is simply to verify that the observed signal is actually a mixing product of the 5, 7, 8, or 9 mixing mode and not operator error. Once this is verified, simply retune to obtain a multiple response of the signal on the $n = 3, 4, 6, \text{ or } 10$ mixing modes.

5. **FREQUENCY.** Coarse tunes analyzer center frequency (tunes analyzer First LO). Drives pointer on CENTER FREQUENCY dial. User has choice of rapid and normal gears in coarse tuning. The exact function of the FREQUENCY depends on SCAN WIDTH (13) and TUNING STABILIZER (8) settings, as follows:

SCAN WIDTH = FULL SCAN. FREQUENCY tunes inverted marker on CRT to indicate center frequency for other SCAN WIDTH positions.

SCAN WIDTH = PER DIVISION. Continuously tunable FREQUENCY determines center frequency of the spectrum displayed. Center Frequency is indicated on linear FREQUENCY BAND SCALE (10).

For SCAN WIDTH PER DIVISION ≤ 100 kHz, the analyzer is automatically stabilized (First LO stabilized to crystal reference) if TUNING STABILIZER (8) is ON. **When stabilized, DO NOT use the FREQUENCY control; use FINE TUNE (6) only.**

Normal continuous tuning action of FREQUENCY can be restored in these narrow SCAN WIDTHS by switching TUNING STABILIZER to OFF. After tuning FREQUENCY, turn TUNING STABILIZER ON to restore stabilization.

SCAN WIDTH = ZERO. FREQUENCY determines analyzer tuning (analyzer acts as fixed frequency receiver). Analyzer is automatically stabilized if TUNING STABILIZER (8) is ON **and** SCAN WIDTH PER DIVISION (12) is set ≤ 100 kHz. To continuously tune FREQUENCY in ZERO SCAN WIDTH, the stabilization must be defeated (switch TUNING STABILIZER to OFF). To tune while stabilized use FINE TUNE (6).

6. **FINE TUNE:** Fine tunes the analyzer center frequency. Use **only** FINE TUNE when analyzer is stabilized, see (5).
7. **FREQUENCY BAND SCALE LEVER:** This lever changes the FREQUENCY BAND SCALE (10) observed in the window. Pulling up on the lever moves the FREQUENCY BAND SCALE (10) toward higher frequency bands and, conversely, pressing down moves the scale toward lower frequency bands.
8. **TUNING STABILIZER:** Analyzer automatically stabilized for SCAN WIDTH PER DIVISION (12) of ≤ 100 kHz when SCAN WIDTH (13) is in either ZERO or PER DIVISION. Stabilization reduces residual FM and drift of the spectrum analyzer. When analyzer is stabilized to a crystal reference, FREQUENCY (5) cannot be used to tune analyzer.
9. **BANDWIDTH:** Selects IF bandwidth (3 dB) to determine analyzer resolution.

10. **FREQUENCY BAND SCALE:** Indicates center frequency to which analyzer is tuned by FREQUENCY (5). Red Hairline indicates center frequency on CRT as well as LO frequency. The mixing harmonic of the LO is indicated on the left-hand side of the FREQUENCY BAND SCALE. When a particular frequency band is selected, all signals falling within that frequency range (that particular mixing mode) are ABSOLUTELY CALIBRATED. The frequency ranges of all the calibrated band scales can be found just below the FREQUENCY BAND SCALE. The green dot in the FREQUENCY BAND SCALE is directly over the particular frequency band chosen by the user.
11. **EXT MIXER BIAS (12.4 - 40 GHz):** Sets external mixer bias level and, hence, sensitivity when using the external waveguide mixer.
12. **SCAN WIDTH PER DIVISION:** Indicates CRT calibration relative to center frequency when SCAN WIDTH (13) is set to PER DIVISION.
13. **SCAN WIDTH:** Selects SCAN WIDTH mode.
 - FULL: First LO scans from 2050 to 4050 MHz. Inverted marker identifies center frequency of other scan modes.
 - PER DIVISION: Scan widths from 2 kHz/DIV to 200 MHz/DIV selectable with PER DIVISION control. Scan is symmetrical about center frequency selected by FREQUENCY (5) and FINE TUNE (6).
 - ZERO: No scan. Analyzer acts as fixed receiver at frequency selected by FREQUENCY (5) and FINE TUNE (6).
14. **AMPL CAL:** Sets overall analyzer gain for absolute amplitude calibration; see CAL OUTPUT (21).
15. **INPUT ATTENUATION:** Attenuates input signal to prevent distortion caused by overload of input mixer. **Input Attenuation** selector sequentially lights IF section index lamps over LOG REF LEVEL/LINEAR SENSITIVITY (27) to indicate correct LOG REF (3c) or LIN scale factor (3a).
16. **DISPLAY UNCAL:** Lights when sweep rate is too fast for bandwidth selected, indicating absolute amplitude calibration is impaired. When warning lamp is lit, either reduce SCAN WIDTH PER DIVISION (12), or increase SCAN TIME PER DIVISION (31), BANDWIDTH (9) or VIDEO FILTER bandwidth to restore calibration.
17. **EXT MIXER (12.4 - 40 GHz):** This port provides the 2.05 - 4.05 GHz first LO output for an external waveguide mixer. This same port also provides a return path for the IF frequency (2.05 GHz) signal from the waveguide mixer. When not in use, this port must be terminated in 50 ohms.
18. **FIRST LO OUTPUT:** This output port provides the first LO output from 2.05 to 4.05 GHz at a +10 dBm level. Future spectrum analyzer accessories will utilize this port. When not in use, this port must be terminated in 50 ohms.
19. **SECOND LO OUTPUT:** This output port provides the second LO output, 1500 MHz at a +10 dBm level. Future spectrum analyzer accessories will utilize this port. When not in use, this port must be terminated in 50 ohms.
20. **RF INPUT:** 50-ohm input connector (Type N).

CAUTION

Care must be taken when applying dc voltage to the RF INPUT of the analyzer. Do **not** change INPUT ATTENUATION setting when dc is applied. Apply only dc voltages with rise time less than 10^6 volts per second and current with rise times less than 2×10^4 amperes per second. With input attenuator in 0 dB position, do **not** exceed ± 20 volts dc. With input attenuator in any other position, do not exceed ± 400 mA dc.

21. **CAL OUTPUT:** -30 dBm ± 0.3 dB output signal at 30 MHz ± 3 kHz (8552B) for amplitude calibration of analyzer.
22. **INDICATOR LAMPS:** When "+" is lit, absolute signal amplitude is the algebraic **sum** of LOG REF LEVEL controls (27) and CRT deflection (3b). When "X" is lit, absolute signal voltage is **product** of LINEAR SENSITIVITY controls (27) and CRT deflection.
23. **PEN LIFT OUTPUT:** Trigger/Blank input. Exact function depends on setting of SCAN MODE (30) and SCAN TRIGGER (28).

Scan Mode	Scan Trigger	Function
INT	EXT	External 2-20 volt signal triggers internal scan ramp generator. Note: Set internal POLARITY SWITCH in 8552B to match trigger pulse polarity.
EXT	EXT	External -1.5 volt signal blanks CRT intensity.
INT OR SINGLE	AUTO LINE OR VIDEO	0-14 volt pen lift output signal (0 V, pen down) for use with pen recorder.

24. **VERTICAL OUTPUT:** Approximately 0-0.8 V for eight division deflection on CRT display; approximately 100 ohms output impedance. Useful for driving vertical channel of pen recorder. With 8552B output is useful for driving headphones also.
25. **SCAN IN/OUT:** Exact function depends on setting of SCAN MODE.

SCAN MODE = INT or SINGLE: Output of approximately 1 volt/DIV scan; analyzer impedance >10 K ohms. External blanking signal to Trigger/Blank Input (23) required.

SCAN MODE = EXT: Input for external 0 to +8 volt scan; analyzer input impedance >10 K ohms. External blanking signal to Trigger/Blank Input (23) required.
26. **DISPLAY ADJUST:** VERTICAL and HORIZONTAL POSITION/GAIN adjustments calibrate analyzer to CRT graticule. See Chapter 4, FRONT PANEL ADJUSTMENTS.

27. **LOG REF LEVEL/LINEAR SENSITIVITY:** Exact function depends on setting of LOG/LINEAR switch.

LOG REF LEVEL (LOG/LINEAR switch set to 2 dB or 10 dB LOG): **Sum** of two control settings determines LOG REF (3c). Step control is adjustable in precise 10 dB increments; vernier control is continuously adjustable from 0 to -12 dB. LOG REF LEVEL scales are all color-coded black to identify the correct scale factor.

LINEAR SENSITIVITY (LOG/LINEAR switch set to LINEAR): **Product** of two control settings is display amplitude deflection factor (volts). Step control adjustable in 1, 2, 10 sequence. Vernier control continuously adjustable from "X1" to "X0.25." Linear sensitivity scales are all color-coded blue to identify correct scale factor.

28. **SCAN TRIGGER:** Operates only with SCAN MODE (30) set to INT. Selects synchronizing trigger for internally generated scan.

AUTO. Scan free runs.

LINE. Scan synchronized to power line frequency.

EXT. Scan initiated by external positive or negative pulses (2 - 20 V) applied to trigger blank input (23).

VIDEO. Scan internally synchronized to envelope of RF input signal. Signal amplitude of 1.5 major divisions peak-to-peak (min.) required on display section CRT.

29. **2 dB LOG/10 dB LOG/LINEAR:** Selects amplitude (vertical) display mode. In 2 dB LOG position CRT is 2 dB/DIV. In 10 dB LOG position CRT vertical scale calibration is 10 dB/DIV. In LINEAR vertical scale calibration is determined by LINEAR SENSITIVITY (27) setting.

30. **SCAN MODE:** Selects scan source.

INT. Analyzer repetitively scanned by internally generated ramp; synchronization selected by SCAN TRIGGER (28). SCANNING lamp (34) indicates duration of scan.

EXT. Scan determined by externally applied 0 to +8 volt signal at SCAN IN/OUT (25). SCAN WIDTH PER DIVISION (12) is operative but not calibrated.

MANUAL. Scan determined by front panel control (33); continuously variable across CRT in either direction. SCAN WIDTH PER DIVISION (12) is operative and calibrated.

SINGLE. Single scan initiated or stopped by front panel pushbutton (32). SCANNING lamp (34) indicates duration of scan. Pushbutton (32) also resets scan.

31. **SCAN TIME PER DIVISION:** Selects time required to scan one major division on CRT display. Also is time base for time domain oscilloscope display in ZERO SCAN mode (13).

32. **PUSH BUTTON** initiates and resets single scan when pressed, see SCAN MODE (30).

- 33. **MANUAL SCAN:** Determines scan when SCAN MODE (30) is set to MANUAL. Scan is continuously variable across the CRT in either direction.
- 34. **SCANNING** lamp indicates duration of scan when SCAN MODE (30) is set to INT or SINGLE.
- 35. **VIDEO FILTER:** Low pass filter for demodulated signal (video envelope of RF input signal). For VIDEO FILTER bandwidth \ll BANDWIDTH (9), video envelope is averaged (useful for averaging broadband random signals, such as noise). VIDEO FILTER bandwidth in OFF is approximately 400 kHz.
- 36. **BASE LINE CLIPPER:** Blanks CRT intensity on lower portion of trace to prevent "blooming" of display due to bright baseline with variable persistence display section (141T). Also useful to prevent fogging of photographs due to bright baseline.
- 37. **CAL, 1 V and 10 V:** 1 volt and 10 volt (peak-to-peak) square waves at power line frequency **for calibration of time domain oscilloscope plug-ins (1400-series) only.**

CAUTION

Never connect these outputs to the RF INPUT (20). Their high amplitude and dc level can damage the input mixer and attenuator.

- 38. **FOCUS:** Control CRT spot size. Adjust with ASTIGMATISM (1) to obtain sharpest definition of trace over entire CRT display.
- 39. **BEAM FINDER:** Intensifies and returns beam to CRT, regardless of deflection potentials **when used with 1400-series time domain oscilloscope plug-ins.**
- 40. **INTENSITY:** Adjusts brightness of CRT display.

CAUTION

Excessive brightness for a static or very slowly moving spot can burn the CRT phosphor and permanently damage the CRT. Particularly avoid excessive brightness with a storage CRT (141T).

- 41. **ERASE:** Entire CRT display erased in WRITE mode.
- 42. **WRITING SPEED—STD:** Greater than 20 cm/msec (storage time more than two hours with reduced INTENSITY).
- 43. **PERSISTENCE:** Adjusts time that stored trace is visible on CRT (fade rate of display). Maximum persistence is determined by writing speed.

Persistence

Std Writing Speed	0.2 second - 1 minute
Fast Writing Speed	0.2 second - 15 seconds

- 44. **WRITING SPEED—FAST:** Greater than 1 cm/ μ sec. (Storage time more than 15 minutes with reduced INTENSITY.)

45. **STORE-TIME:** Trace last displayed with WRITING SPEED STD (42) is stored for more than two hours with reduced brightness and more than one minute at maximum brightness. Storage time, brightness, and background illumination are determined by TIME knob setting.
46. **PILOT LAMP** indicates POWER (47) is in ON position.
47. **POWER** ac line switch.
48. **NONSTORAGE—CONV:** In this mode of operation, CRT persistence is normal (approximately 0.1 second).
49. **POWER AC:** Line switch and pilot light.
50. **CALIBRATION SCALE:** Plot of 8445B insertion loss versus frequency. The insertion loss of the 8445B is added to the measured signal amplitude on the screen of the 8555A Spectrum Analyzer to maintain absolute calibration.
51. **MANUAL TUNE:** COARSE and FINE tune determine center frequency of bandpass when MODE (54) switch is in MANUAL (54b) position.
52. **TRACKING:** Screwdriver adjustment for tracking range of 8445B.
53. **FREQ OFFSET:** Allows a fine frequency offset adjustment to insure that pre-selector is precisely tracking the spectrum analyzers.
54. **MODE:** There are four possible modes of operation in an 8445B:
 - a) **AUTO:** This mode results in completely automatic operation with the 8555A Spectrum Analyzer over the frequency range 0.01 - 18 GHz. (1.8 - 18 GHz with Option 004.)
 - b) **MANUAL:** This mode allows the use of 8445B as a manually tunable filter with center frequency determined by MANUAL COARSE TUNE and MANUAL FINE TUNE (51) (available with Option 002 only).
 - c) **LOW PASS:** In this mode, a passive low pass filter with cut-off frequency at 1.8 GHz is connected to the input voltage amplitude. The proportionality is 1 volt/GHz.
55. **INPUT and OUTPUT ports:** The 8445B is a unilateral filter and hence the filter input and output must be observed. Signals of interest enter the INPUT. The OUTPUT port is connected directly to spectrum analyzer input port.

Unfold for Figure 22.

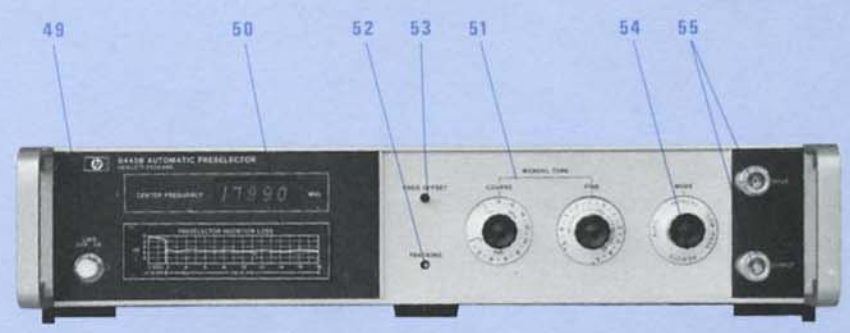
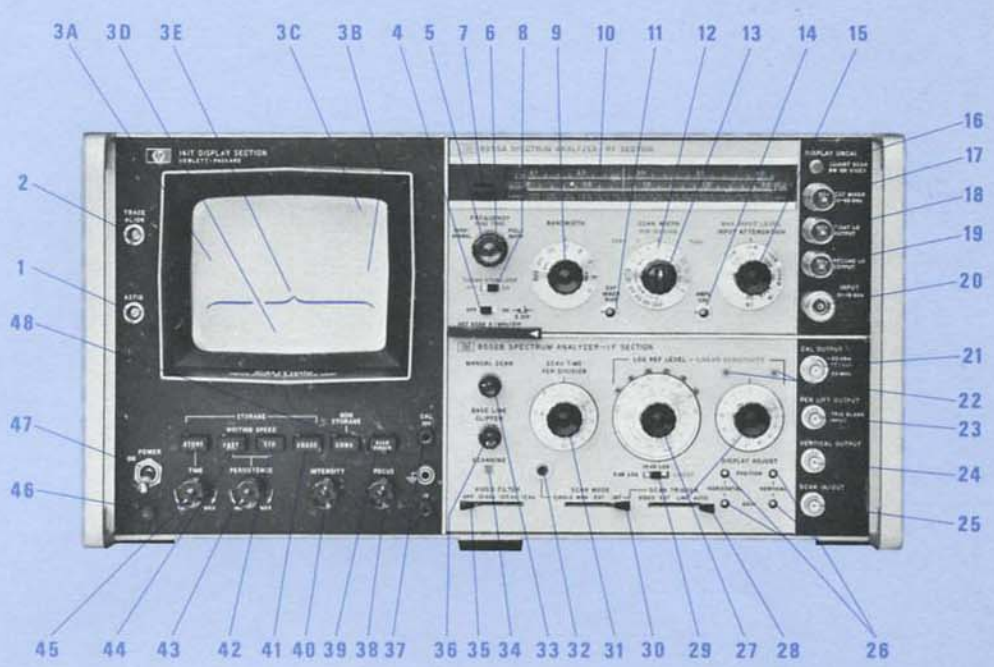

Figure 22. 8555A/8552B/141T/8445B Option 002, 003 Microwave Spectrum Analyzer.

CHAPTER 4

FRONT PANEL ADJUSTMENTS

The front panel adjustments optimize the performance of a particular RF section, IF section, and display section and preselector combination. These adjustments must be made whenever any one of these three analyzer sections or preselector is changed. Once initial adjustment has been made for a particular system the system should maintain calibration. However, it is a good idea to check the calibration of the system occasionally with the calibrator output in the IF section and check the tracking of the preselector with the **FREQ OFFSET** adjustment.

Since the making of front panel adjustments is a good exercise in making you more familiar with the 8555A Spectrum Analyzer, it is included in this note.

1. **Initial Control Settings:** Turn your analyzer ON and set **INTENSITY** to approximately 1 o'clock. While the analyzer is warming up, make the following control settings:

FREQUENCY BAND SCALE	0 - 2.05 GHz Band
FREQUENCY	30 MHz
FINE TUNE	Center of Range
BANDWIDTH	300 kHz
SCAN WIDTH	Per Division
SCAN WIDTH/PER DIVISION	200 MHz/Division
INPUT ATTENUATION	10 dB
TUNING STABILIZER	On
SIGNAL IDENTIFIER	Off
BASE LINE CLIPPER	Max CCW
SCAN TIME PER DIVISION	10 Seconds
LOG REF LEVEL	Max CCW
LOG/LINEAR	Log
VIDEO FILTER	Off
SCAN MODE	Internal
SCAN TRIGGER	Auto
WRITING SPEED	Std
PERSISTENCE	Max CCW

2. **Display Section Adjustments:** **FOCUS**, **ASTIGMATISM**, and **TRACE ALIGN**.

- a) Adjust **FOCUS** and **ASTIGMATISM** for smallest round dot possible.
- b) Reset **SCAN TIME PER DIVISION** to 1 ms. Adjust **TRACE ALIGN** so that horizontal base line of the CRT trace is exactly parallel to the horizontal graticule lines.

3. **IF Section Adjustments:** HORIZONTAL POSITION/GAIN.

- a) Rotate HORIZONTAL GAIN until the trace is of minimum length.
- b) Rotate HORIZONTAL POSITION until trace is centered on CENTER FREQUENCY line of the graticule.
- c) Alternately adjust HORIZONTAL POSITION and HORIZONTAL GAIN controls until the trace fills the screen and begins at the first line of the CRT graticule and ends at the last.

4. **IF Section Adjustments:** VERTICAL, POSITION/GAIN.

RF Section Adjustments: AMPL CAL.

- a) Adjust vertical position until trace aligns with bottom line of graticule.
- b) Connect the CAL OUTPUT (30 MHz/−30 dBm) signal to the RF input. This signal is the absolute calibration for the spectrum analyzer. The 30 MHz fundamental and all its harmonics are present. However, only the 30 MHz fundamental is amplitude calibrated at −30 dBm. The higher order harmonics are less in amplitude. In amplitude calibration of the analyzer, therefore, we must be careful to use the fundamental 30 MHz signal.
- c) Set LOG REF LEVEL to −10 dBm. SCAN WIDTH to PER DIVISION. Narrow SCAN WIDTH PER DIVISION to 10 MHz/DIV. Note the large amplitude signal near the −3 graticule. The peak of the signal should be off screen. This is the LO feedthrough. The LO feedthrough is left of the 30 MHz signal by 3 divisions. Center the 30 MHz signal in the display and narrow scan width to 0.2 MHz/DIV.
- d) Change LOG REF LEVEL to −30 dBm. Rotate LOG REF VERNIER until peak of signal aligns with a major division on the graticule.
- e) Step the LOG REF LEVEL counterclockwise. The signal amplitude should decrease in exactly 10 dB steps. Adjust the VERTICAL GAIN until the signal increments are as close to 10 dB steps as possible. See Figure 23. **RETURN LOG REF VERNIER TO 0** and LOG REF to −10 dBm.
- f) Adjust AMPL CAL until signal peaks at exactly −30 dBm. The analyzer is now calibrated in the LOG display mode.

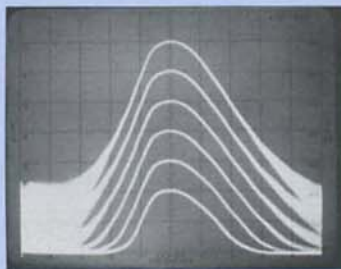

Figure 23. Signal amplitude changes as LOG REF LEVEL is stepped.

5. **AMPLITUDE CAL fine adjustment with LINEAR SENSITIVITY accuracy:** In the LINEAR display mode the vertical display is calibrated in **absolute voltage**. For LINEAR measurements the LIN scale factors on the left side of the CRT and the blue color-coded scales of the LINEAR SENSITIVITY controls are used. The signal voltage is the **product** (note lighted "x" lamp) of the CRT deflection and LINEAR SENSITIVITY control settings. It is usually most convenient to normalize the LINEAR SENSITIVITY vernier by setting it to "1."

- a) Set the LOG/LINEAR switch to LINEAR. Set LINEAR SENSITIVITY to 1 mV/div (1 mV x 1). Since the -30 dBm Calibrator output is 7.07 mV (across 50 ohms), the CRT deflection should be 7.07 divisions.
- b) Adjust AMPL CAL on 8555A for a 7.07 div CRT deflection, if necessary. (LINEAR display is more expanded than the compressed LOG display, so adjustment of the AMPL CAL control can be made with more resolution in LINEAR without noticeable effect on the LOG calibration).

The analyzer is now calibrated for both the LOG and LINEAR display modes. The remaining adjustments, the TRACKING and OFFSET, on the front panel of the 8445B ensure that the 8445B will precisely track an 8555A on all bands. A signal source is necessary for the following procedure. We will use the same source as in the operating procedure, the 8616A signal generator.

6. **Initial Spectrum Analyzer Control Settings:**

FREQUENCY BAND SCALE	n = 2- (2.07 - 6.15 GHz)
FREQUENCY	2200 MHz
BANDWIDTH	300 kHz
SCAN WIDTH	5 MHz Per Division
INPUT ATTENUATION	10 dB
TUNING STABILIZER	On
SIGNAL IDENTIFIER	Off
BASE LINE CLIPPER	Adjust for Convenient Display Without Blooming
SCAN TIME PER DIVISION	5 ms/Division
LOG REF LEVEL	0 dBm
LOG REF LEVEL VERNIER	0
LOG/LINEAR	Log
VIDEO FILTER	Off
SCAN MODE	Internal
SCAN TRIGGER	Auto
WRITING SPEED	Std
PERSISTENCE	Max CCW

7. Turn ON 8616A signal generator. Depress the ALC button on the signal generator and adjust the ALC CAL OUTPUT knob setting until the meter reads 0 dBm. The signal generator is now calibrated. Set the output attenuator to 0 dBm and frequency to 2200 MHz.
8. Turn ON the 8445B Preselector. Connect the INPUT of the 8445B Preselector to the OUTPUT of the 8616A Signal Generator. Connect the OUTPUT of the 8445B Preselector to the INPUT of the 8555A Spectrum Analyzer.
9. The signal of interest should be in near-center screen. Adjust the OFFSET to maximize the signal amplitude.
10. Change signal generator frequency to 4000 MHz and the spectrum analyzer FREQUENCY BAND SCALE to $n = 2+$ (6.17 - 10.25 GHz). Measure the 8 GHz second harmonic amplitude on screen. Adjust TRACKING so that signal increases in amplitude and reaches a peak.
11. Return signal generator frequency to 2200 MHz and FREQUENCY BAND SCALE to $n = 2-$ (2.07 - 6.15 GHz). Adjust OFFSET as before.
12. Tune signal generator frequency to 4000 MHz and change BAND to $n = 2+$ (6.17 - 10.25 GHz). Check that signal second harmonic amplitude is at maximum by rotating OFFSET slightly in either direction. Signal amplitude should not increase. Make final adjustments by adjusting TRACKING at 8000 MHz and OFFSET at 2200 MHz as above.

The preselector is now precisely tracking the spectrum analyzer. Once these adjustments have been completed for a particular preselector, no further adjustment should be necessary. However, it is a good idea to check tracking occasionally by offsetting the frequency of the 8445B slightly with OFFSET. Signal amplitude should decrease as frequency is offset from the correct setting.

CHAPTER 5

OPERATING THE SPECTRUM ANALYZER

This short operating procedure uses the 8616A Signal Generator and the ET-2399A Signal Source to demonstrate the important features of the 8555A/8552A or 8555A/8552B system. (Any 30 MHz **stable** source may be used.)



Figure 24. 8616A Signal Generator.

The 8616A provides signals to observe and identify at microwave frequencies (1800 - 4500 MHz). In addition, the 8616A provides a calibrated output useful for demonstrating absolute calibration and flat frequency response.

The ET-2399A (modified ET-2399) Signal Source provides a precise, stable 30 MHz signal from a crystal oscillator. This signal source has enough stability to demonstrate the full capability of the 8555A measurement system.

This signal can be amplitude modulated (up to about 40%) at either 650 Hz or 10 kHz. This simple source simulates a wide variety of measurement situations such as are commonly encountered in a lab. While making these measurements, you will see the benefits of **fast, accurate, swept** wave analysis.

Note:

The ET-2399A is powered from a standard 8.4 V transistor radio mercury battery. (A 9 V carbon zinc battery can be used as an emergency replacement.) With normal operation, the battery will last about 50 hours (including accidental briefcase operation). A spare battery is included under the top cover of the ET-2399.

Any other stable source may be used in this procedure. For example, the HP 8660-series of signal generators.

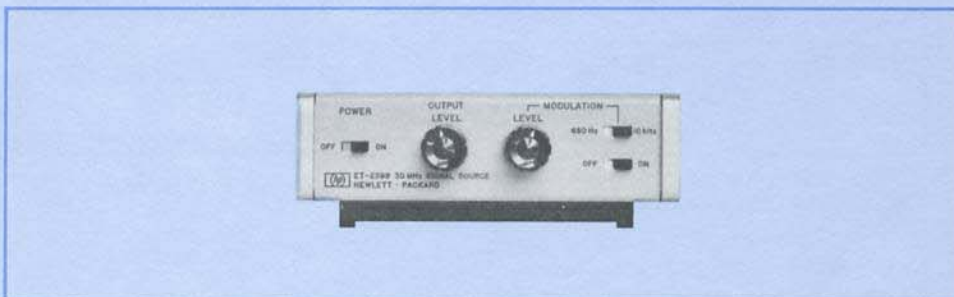

Figure 25. ET-2399A Front Panel Controls.

INSTRUMENT INITIAL SET-UP

1. Turn the signal generator and spectrum analyzer on. Depress the ALC button on the signal generator and adjust the ALC CAL OUTPUT knob setting until the meter reads 0 dBm. The signal generator is now calibrated. Set the output attenuator to 30 dB and frequency at 4500 MHz. Connect the RF CAL output of the 8616A to the RF input of the 8555A.
2. Make the following control settings on the spectrum analyzer:

FREQUENCY BAND SCALE	Green Dot Over 0 - 2.05 GHz Range
SCAN WIDTH	Full
INPUT ATTENUATION	10 dB
TUNING STABILIZER	Off
SIGNAL IDENTIFIER	Off
SCAN TIME PER DIVISION	20 ms
SCAN WIDTH	200 MHz/DIV
BANDWIDTH	300 kHz
LOG/LINEAR	10 dB Log
LOG REF LEVEL (Vernier set to 0)	-10 dBm
VIDEO FILTER	Off
SCAN MODE	Internal
SCAN TRIGGER	Auto
BASE LINE CLIPPER	Max CCW
PERSISTENCE	Max CCW
WRITING SPEED	Std
INTENSITY	Adjust for Good Contrast Without Blooming

The display should be similar to Figure 26.

Note that three signals are present. These are multiple responses of the spectrum analyzer to an input signal.

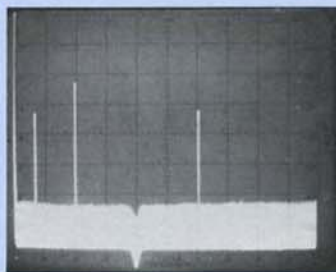

Figure 26.

TUNING AND SIGNAL IDENTIFICATION

3. Because of multiple and image responses which occur in any harmonic mixing analyzer, every signal observed on the CRT must be identified. Select one of the three observed signals. To identify the signal, tune FREQUENCY so that the inverted marker is under the signal. A null in signal amplitude will be seen. (Note the convenience in the choice of normal and rapid gears for coarse tuning.) Set SCAN WIDTH to 10 MHz/DIV and BANDWIDTH to 30 kHz. Change scan mode from FULL SCAN to PER DIVISION. Unknown signal is now in center screen as in Figure 27.

Benefit:

All input signals are displayed **simultaneously** in full scan mode. The signal of interest can be **selected** with the inverted marker and expanded to relatively narrow scan width without constant returning as scan width and bandwidth are changed.

4. Set SCAN WIDTH PER DIVISION to 1 MHz/DIV, keeping signal centered. Turn SIGNAL IDENTIFIER on. Note that another signal appears on the CRT which is slightly less in amplitude than the signal of interest. Advance the FREQUENCY BAND SCALE by pushing up on the lever until the smaller signal is two divisions to the left of the original signal. (Figure 28.) This condition (as described in the engraving on the front panel near the signal identifier switch) indicates that the correct frequency band scale has been chosen. The frequency of the signal can be read under the hairline as 4.50 GHz.

Benefit:

Signal identification is a **simple** procedure with the 8555A.

ABSOLUTE AMPLITUDE CALIBRATION

5. Turn SIGNAL IDENTIFIER OFF. Read absolute signal amplitude using CRT graticule (remember LOG REF is -10 dBm). Compare to calibrated signal generator output. The absolute calibration of the 8616A is ± 1.5 dB. Turn SCAN MODE to FULL. Select each of the other two signals in suc-

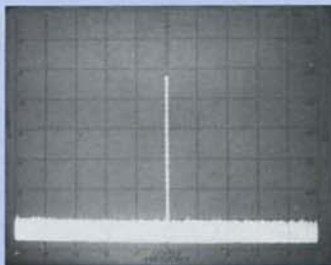

Figure 27.

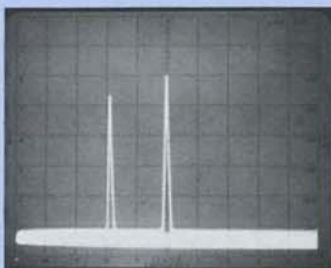

Figure 28.

cession, identify them, and compare the measured amplitude to the calibrated signal generator.

Benefit:

8555A is **absolutely** calibrated. This makes possible **absolute power** measurement as well as **direct comparisons** of two signals on different frequency scales.

6. Change INPUT ATTENUATION from 10 dB to 20 dB. Signal amplitude on display is attenuated 10 dB. Note that the index lamp above the LOG REF LEVEL control has also changed, indicating the LOG REF LEVEL is now 0 dBm. The absolute amplitude calibration is preserved since the sum of the new LOG REF LEVEL and the new CRT deflection is the same as in Step 5. Return INPUT ATTENUATION to 10 dB.

Benefit:

Absolute amplitude calibration is maintained regardless of control settings.

7. Switch LOG/LINEAR to LINEAR and switch LINEAR SENSITIVITY for deflection within CRT graticule. Measure the signal voltage: Signal Voltage = (Linear Sensitivity) x (CRT Deflection). (It is usually most convenient to normalize the LINEAR SENSITIVITY vernier by setting the LINEAR SENSITIVITY vernier to "X1.") Signal voltage = 7.07 mV.

Benefit:

Absolute amplitude calibration for voltage measurements with the spectrum analyzer.

8. Adjust LINEAR SENSITIVITY controls for a deflection of 4 - 8 divisions. Switch SCAN WIDTH successively to 20 and 50 MHz/DIV. Note that when display amplitude is reduced (SCAN TIME too fast for BANDWIDTH and SCAN WIDTH), the amber DISPLAY UNCAL warning lamp lights. With SCAN WIDTH 20 MHz/DIV, decrease SCAN TIME until analyzer is absolutely calibrated.

Benefit:

When the analyzer is operating outside of its absolutely calibrated region due to incompatible settings of SCAN TIME, SCAN WIDTH, BANDWIDTH, and VIDEO FIL-

TER, the operator is alerted by DISPLAY UNCAL lamp, thus preventing possible operator error. The operator can then change the settings of any of these four controls to maintain absolute calibration.

AUTOMATIC PRESELECTION

9. Make the following spectrum analyzer control settings:

FREQUENCY BAND SCALE	Green Dot Over 4.11 - 6.15 GHz Range
SCAN MODE	Full
INPUT ATTENUATION	10 dB
SCAN TIME PER DIVISION	20 ms
LOG/LINEAR	10 dB Log
LOG REF LEVEL (Vernier set to 0)	-10 dBm

Note the three responses of the spectrum analyzer to the 4500 MHz input signal. These are multiple responses. See Figure 29A.

10. Connect the OUTPUT of the 8616A signal generator to the INPUT of the 8445B Preselector. Connect the OUTPUT of the 8445B Preselector to the INPUT of the 8555A Spectrum Analyzer. Note that only one signal appears on the CRT instead of three. See Figure 29B.

Benefit:

A preselector **eliminates** multiple responses.

11. Tune FREQUENCY until the notch is positioned under the signal. Read the frequency directly off the band scale. Repeat for FREQUENCY BAND SCALE settings of $n = 2$ — (2.07 - 6.15 Hz) and $n = 3$ — (4.13 - 10.25 GHz).

Benefit:

A preselector makes signal identification unnecessary. In addition, the operation of the 8445B Preselector is completely **AUTOMATIC**. The user is free to concentrate on the measurement itself.

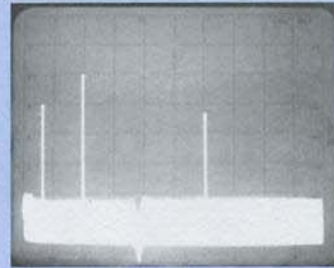

Figure 29A.

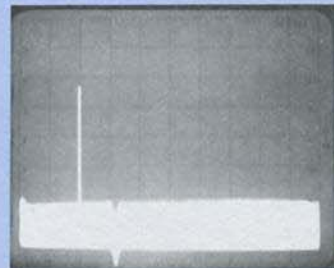

Figure 29B.

- Return the FREQUENCY BAND SCALE to the $n = 1+$ (4.11 - 6.15 GHz) range. Measure the amplitude of the signal. Add to this amplitude the insertion loss of the preselector at 4500 MHz. The insertion loss can be read off the CALIBRATION SCALE of the preselector. Compare the sum of the addition above to the signal level of the calibrated signal generator.

Benefit:

Absolute calibration is maintained when using the 8445B Preselector.

- Advance the FREQUENCY BAND SCALE to the $n = 3-$ (4.13 - 10.25 GHz). Note the frequency end points of the band scale. In the FULL SCAN mode these are the frequency end points of the CRT. The effective scan width then is 6 GHz. The maximum scan in SCAN WIDTH PER DIVISION mode is 200 MHz/DIV or a total CRT scan of only 2 GHz.

Benefit:

By allowing the use of the FULL SCAN mode for **measurements**, not just observation of signal of interest, the preselector increases the scan width range of the 8555A. The maximum scan width is 8 GHz/10 DIV on the $n = 4$ mixing mode.

- Disconnect signal generator output cable from INPUT of preselector and connect to INPUT of spectrum analyzer. Change signal generator frequency to 2500 MHz. Change FREQUENCY BAND SCALE to the $n = 2-$ (2.05 - 6.15 GHz) mixing mode. Set the output attenuator in 8616A Signal Generator to -15 dB. Notice the increase in harmonic distortion products. See Figure 30A. Reconnect the preselector. Note the disappearance of the distortion products as well as multiple and image responses. See Figure 30B.

Benefit:

The 8445B Preselector allows the use of higher input signal levels without the generation of spurious products in the input mixer of the spectrum analyzer.

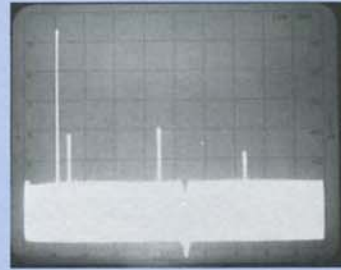

Figure 30A.

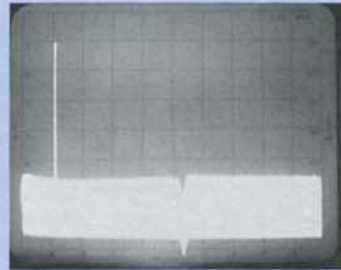

Figure 30B.

- Disconnect the 8445B Preselector OUTPUT cable from the INPUT of the spectrum analyzer. Connect the OUTPUT of the signal generator to the INPUT of the spectrum analyzer.

Benefit:

The fact that the preselector circuitry is in a **separate package** means it can be connected or disconnected at will. Disconnecting the preselector means an improvement in sensitivity and frequency response of the spectrum analyzer.

FREQUENCY FLATNESS

- Return output attenuator of 8616A Signal Generator to 30 dB. Set signal generator frequency to 2500 MHz. Make the following spectrum analyzer settings:

FREQUENCY BAND SCALE	Green Dot Over 1.5 - 3.55 GHz Range
FREQUENCY	2.5 GHz
SCAN WIDTH	100 MHz/DIV
BANDWIDTH	300 kHz
LOG/LINEAR	Log
LOG REF LEVEL	-10 dBm
BASE LINE CLIPPER	Adjust to Remove Baseline
PERSISTENCE	Max CW
INTENSITY	Adjust for Good Contrast Without Blooming

- Set signal generator frequency at 2 GHz and slowly increase continually to 3 GHz. This will trace out the frequency response of the analyzer over this frequency range. See Figure 31. The frequency response of the analyzer is typically flat to ± 1 dB. (The amplitude output variation of the 8616A is typically ± 0.5 dB and this contributes to the observed frequency variation.)

Benefit:

The 8555A has an exceptionally **flat frequency response**. This is essential for both relative and absolute signal measurements.

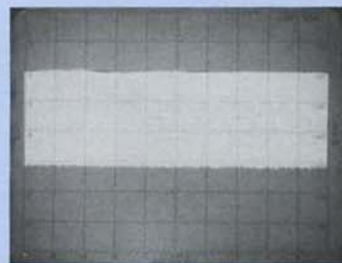

Figure 31.

FREQUENCY LINEARITY

18. Disconnect the 8616A signal generator from the spectrum analyzer. Set spectrum analyzer controls as in Step 2. Change scan mode to PER DIVISION and SCAN WIDTH to 10 MHz/DIV. Connect ET-2399A demo source to the spectrum analyzer. Turn ON the ET-2399A. Tune FREQUENCY to 60 MHz (second harmonic of source frequency). Use FREQUENCY to align the observed signals with the vertical lines in the CRT. Note that the signals in Figure 32 are spaced exactly 3 divisions (30 MHz) apart.

Benefit:

Excellent frequency linearity means that both **relative** and **absolute frequency** of displayed signals can be measured easily and accurately.

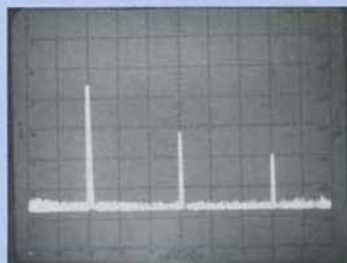

Figure 32.

SENSITIVITY

19. Tune FREQUENCY to higher order harmonic of source. Adjust amplitude so that signal almost disappears. Set LOG REF LEVEL so that peak level is in near-center screen. Set SCAN WIDTH to 0.2 MHz/DIV, BANDWIDTH to 30 kHz, and SCAN TIME to 50 msec/DIV. See Figure 33A. Signal is barely visible in the noise. Step VIDEO FILTER through the 10 kHz and 100 Hz positions. See Figure 33B. Note the improvement.

Benefit:

VIDEO FILTER improves the signal visibility for coherent (CW) signals by averaging noise.

20. Temporarily disconnect the signal source from the analyzer. Make the following spectrum analyzer settings:

BANDWIDTH	0.1 kHz
SCAN WIDTH	2 kHz/DIV
INPUT ATTENUATION	0 dB
SCAN TIME	1 sec
LOG REF LEVEL	-60 dBm

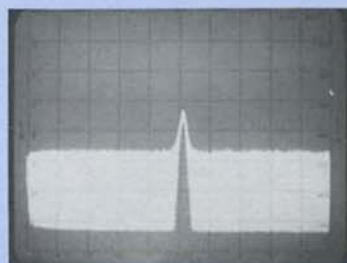

Figure 33A.

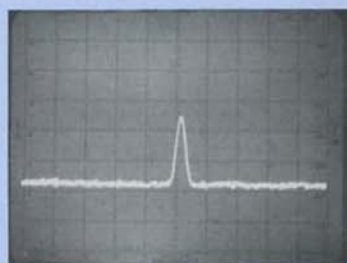

Figure 33B.

VIDEO FILTER	100 Hz
PERSISTENCE	Max CCW
INTENSITY	Adjust for Good Contrast Without Blooming

Read the **average** noise level. See Figure 34. (On the 0 - 2.05 GHz frequency band, average noise level is typically -130 dBm for 100 Hz bandwidth.) The average noise level determines the sensitivity of the analyzer.

Benefit:

The **increased sensitivity** of the 8555A improves the signal amplitude measurement range. Also note that the VIDEO FILTER can be used to average "distributed" signals (such as noise) to **measure average power per unit bandwidth**; e.g., noise density.



Figure 34.

TUNING STABILIZATION

21. Reset the spectrum analyzer controls as in Step 2. Reconnect the ET-2399A signal source. Tune FREQUENCY to 30 MHz. Set SCAN MODE to PER DIVISION, decrease BANDWIDTH to 0.3 kHz, and SCAN WIDTH to 5 kHz/DIV. Some change in coarse FREQUENCY and FINE TUNE may be necessary to keep signal in near-center screen. Note the instability of the trace. See Figure 35A. Turn the TUNING STABILIZER ON. See Figure 35B. HP's unique automatic stabilization circuit eliminates tedious adjustments to lock the analyzer. You don't even have to operate the TUNING STABILIZER switch! Simply leave the switch ON all the time. The analyzer will be automatically stabilized for the blue-coded SCAN WIDTHS when in PER DIVISION and ZERO SCAN positions.

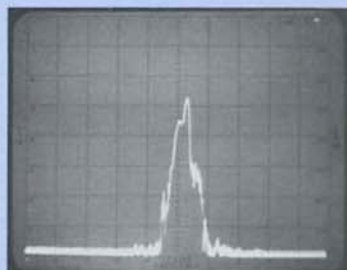

Figure 35A.

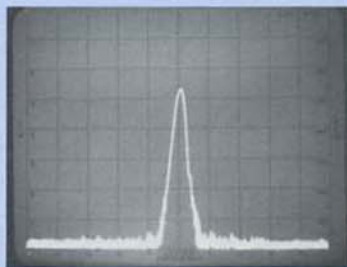

Figure 35B.

Benefit:

Automatic stabilization results in ease of operation.

22. Center the signal using FINE TUNE only. Decrease BANDWIDTH to 100 Hz. Reduce SCAN TIME to 1 sec/DIV. Increase PERSISTENCE to obtain a readable display on

screen. Note the extreme **resolution** and **rock-solid** stability. (Dim the bright baseline of the trace with the BASE LINE CLIPPER.)

Benefit:

Variable Persistence allows the user to obtain an easily readable display when using the high resolution capabilities of the 8555A.

23. Select 10 kHz modulation on the ET-2399A. Set SCAN WIDTH to 2 kHz/DIV. Switch MODULATION ON and turn MODULATION LEVEL approximately 1/4 turn. Note the 10 kHz sidebands on the carrier. (Figure 36.) Change BANDWIDTH to 1 kHz (this is the minimum bandwidth offered by other microwave spectrum analyzers). Note the difference in resolving capability. (Figure 37.)

Benefit:

The **high resolution** capability of the 8555A enables the user to better distinguish two signals close together in frequency and in particular low level sidebands close to a carrier.

The amplitudes on the display in Figure 36 are asymmetrical because the modulator in the ET-2399A produces incidental FM as well as the desired AM. (Lower FM and AM sidebands are adding in-phase; upper FM and AM sidebands are adding out-of-phase.) Note second harmonic (and higher order) distortion sidebands. These sidebands are typically 20 dB below the fundamental sidebands, corresponding to 10% second harmonic distortion.

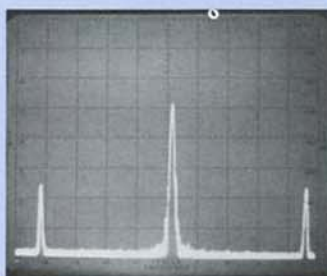

Figure 36.

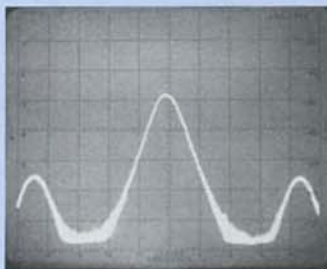

Figure 37.

ZERO SCAN

24. Set ET-2399A for maximum MODULATION LEVEL at 10 kHz. Make the following spectrum analyzer settings:

BANDWIDTH	30 kHz
SCAN WIDTH	100 kHz/DIV
SCAN TIME	0.2 ms/DIV
PERSISTENCE	Min (Full CCW)

Center signal on display carefully. Switch LOG/LINEAR to LINEAR and turn LINEAR SENSITIVITY CCW for an on-screen display (about 1 mV/DIV). Adjust LINEAR SENSITIVITY vernier for convenient display amplitude. Set SCAN WIDTH to ZERO SCAN. Synchronize the display by setting SCAN TRIGGER to VIDEO. The analyzer is now operating as a fixed frequency receiver at 30 MHz with a 30 kHz bandwidth. Its detected output, the 10 kHz sine wave, is displayed in **time domain** on the oscilloscope CRT, Figure 38.

Benefit:

The analyzer can also be used in **time domain** to display the detected output of amplitude modulated signals. The SCAN TIME control is now the **calibrated time base** of the oscilloscope.

Note:

Frequency modulated signals can also be detected and displayed in time domain. In this case the signal is not tuned to the center of the analyzer passband but on the skirt of the passband, instead. It is then "slope-detected" and displayed in time domain on the CRT. (Slope detection will provide some response to any AM present, also.)

The 8555A brings QUANTITATIVE performance for the first time to microwave spectrum analysis. Both amplitude and frequency are absolutely calibrated. In addition, the 8555A is also easier to operate than previous microwave analyzers. Hence, the 8555A offers **simple, accurate, swept analysis** in the microwave frequency domain . . . analysis that will help you solve your measurement problems.

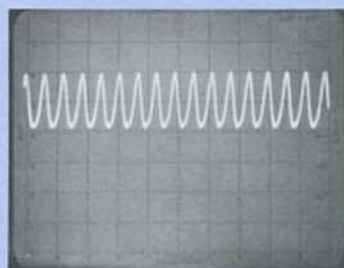

Figure 38.

APPENDIX I

THEORY OF OPERATION

INTRODUCTION

With the aid of the simplified block diagram in Figure 39 and by drawing an analogy to a radio receiver, we can better understand how a spectrum analyzer functions. A knowledge of the functioning of a spectrum analyzer is invaluable in understanding specifications, spotting applications, etc. After consideration of the operation of the total spectrum analyzer package, we will focus our attention on the RF Section only, the 8555A.

BASIC SYSTEM DESCRIPTION

The 8555A/8552B is basically a superheterodyne receiver with an electronically swept LO. See Figure 39. **FOLD PAGE 41 OUT SO IT CAN BE SEEN WHILE READING THE THEORY OF OPERATION.** The first LO in the 8555A is the only LO that is swept. The amplitude of the sweep is determined by the Scan Width Attenuator which attenuates the Scan Ramp driving the LO. As in a superheterodyne receiver, the input signal is heterodyned down. In the 8555A system, heterodyning is successive to IF's of 2050 MHz, 550 MHz, 50 MHz, and 3 MHz. The 3 MHz IF bandwidth is adjustable to control the overall resolution of the analyzer. Either linear or logarithmic amplification can be selected in the 3 MHz IF. A superheterodyne receiver utilizes a potentiometer to control the degree of audio amplification. In the 8555A Spectrum Analyzer system, amplification is controlled with a precision step attenuator in the 3 MHz IF. The output of the 3 MHz IF is then detected.

The detected output in the analyzer is amplified and then applied to the vertical deflection plates of the CRT. The horizontal plates are driven by the same ramp voltage that sweeps the first LO. Thus, as the analyzer is electronically tuned through its frequency range, a visual display of the spectral components present at the analyzer's input will be traced out on the CRT. Much in the same way, manually tuning a radio receiver from the low end of the dial to the high end will result in the spectral components in the AM radio band (broadcast stations) being heard successively in the loudspeaker in order of increasing frequency.

8555A RF SECTION

The dotted lines in Figure 40 delineate the circuits contained in the RF section. **FOLD PAGE 43 OUT SO THAT IT CAN BE SEEN WHILE READING THE REST OF THIS APPENDIX.** Since it contains the first mixer and local oscillator, the RF section of a spectrum analyzer determines the frequency range the analyzer is to cover. The 8555A RF Section operates over the range of 10 MHz to 18 GHz with internal mixing and 12.4 to 40 GHz with external mixing. Besides determining the frequency range, the RF Section plays an important role in determining the overall operating specifications of the spectrum analyzer system. Some of the key system parameters, such as frequency response, sensitivity, and frequency stability, hinge on the performance of the first frequency down converter in the RF Section.

Because of the importance of the RF Section, we will consider it in more detail.

INPUT MIXER

The input mixer in the 8555A is a Schottky diode and a silicon transistor on a microcircuit substrate. Through the use of microcircuit techniques, exceptionally flat frequency response is achieved. The flat frequency response of the input mixer is one of the key factors necessary for absolute amplitude calibration. Another key factor is providing appropriate amplitude compensation. Why is this compensation necessary?

1. Depending on the particular harmonic of the local oscillator used in mixing, the mixer conversion loss is different.
2. Despite the exceptional flatness of the input mixer, there is some fall-off in response at higher frequencies.

Compensation for 1 and 2 above occurs in the 50 MHz IF amplifier. See Figure 40. The **frequency band scale lever** controls a shaft encoder that performs several functions. One function is to control the gain of the 50 MHz IF amplifier to compensate for differences in mixer conversion efficiency in higher order mixing modes. The scan ramp also controls the gain of the 50 MHz amplifier to compensate for slight mixer frequency roll-off at the higher frequency end of the LO sweep. Through these compensations, absolute calibration is preserved.

FIRST LOCAL OSCILLATOR

The resonant element in the first local oscillator is a YIG (Yttrium-Iron-Garnet) sphere. The resonant frequency is controlled by currents flowing in the main drive coil and tickler drive coil indicated in Figure 40. For scans in excess of 500 kHz per division, the YIG is driven by a ramp applied to the main drive coil. For scans ≤ 500 kHz per division, the YIG is driven by a ramp voltage applied to the tickler coil. The scan attenuator determines the width of the sweep. The SCAN WIDTH PER DIVISION knob in the front panel controls this attenuator.

In a harmonic mixing analyzer the "effective sweep" is a function of mixing mode. Consider the following example: On fundamental mixing in FULL SCAN, the sweep range of the LO is 2 - 4 GHz; but on the second harmonic, the LO sweep range is 4 - 8 GHz. The scan ramp to the horizontal plates of the CRT remains unchanged, however. The net effect then is to double the "effective sweep width" on the CRT to a total of 4 GHz instead of 2 GHz. This explains why the FREQUENCY BAND SCALES corresponding to higher mixing modes or higher "n" numbers cover more frequency range in GHz; i.e., for $n = 1$ the frequency range between band scale end points is 2 GHz (LO fundamental scans 2 - 4 GHz); for $n = 4$ the frequency range between band scale end points is 8 GHz (LO 4th harmonic scans 8 - 16 GHz). In this way, the analyzer maintains calibration of the horizontal scale of the CRT in FULL SCAN for different harmonic mixing modes.

Another technique is used to maintain horizontal scale calibration in the SCAN WIDTH PER DIVISION mode where the SCAN WIDTH control determines the end points of the horizontal axis. To maintain the calibration of SCAN WIDTH PER DIVISION for such a case, the LO scan ramp is controlled by a $1/n$ (where $n =$ mixing mode) attenuator. Let's consider our example of second harmonic mixing again. Let SCAN WIDTH PER DIVISION be 200 MHz/DIV. On fundamental mixing the "effective scan width" is 2 GHz full screen. However, the "effective scan width"

is doubled on the screen for second harmonic mixing. The 1/n attenuator would multiply the LO scan ramp by $\frac{1}{2}$ in this case. This cancels the doubling of the "effective scan width" and the calibration of SCAN WIDTH PER DIVISION is maintained. The shaft encoder on the FREQUENCY BAND SCALE LEVER controls the 1/n attenuator automatically.

AUTOMATIC STABILIZATION

For narrow scans the residual FM of the YIG oscillator becomes more noticeable and stabilization is necessary. To stabilize the first local oscillator, the STABILIZER must be ON and the SCAN WIDTH PER DIVISION ≤ 100 kHz. The frequency reference is a crystal-controlled 1 MHz oscillator. When stabilized, the LO locks to a harmonic of this oscillator. For small tuning changes in the FREQUENCY control, the stabilization system generates correction signal to retune the LO exactly to the same harmonic of the 1 MHz frequency reference oscillator. For large tuning changes in the FREQUENCY control, the first LO jumps to some other harmonic of the 1 MHz reference oscillator. Hence, when the LO is stabilized, FREQUENCY **cannot** be used to tune the YIG. It is, therefore, necessary to use only FINE TUNE to tune the YIG while stabilized.

Prior to stabilization, the first LO is usually not operating exactly at a harmonic of 1 MHz. Therefore, closing the stabilization loop may change the first LO by as much as 500 kHz to bring it into synchronism with the reference oscillator. If no compensation were made for this effect, there would be a frequency offset of the signals on analyzer's CRT display at the time the TUNING STABILIZER was enacted. To prevent this, the reference oscillator is brought into synchronism with the LO rather than vice versa. Stabilization occurs in a series of steps controlled by the control generator. First, switch A in Figure 40 is closed. The error voltage due to lack of synchronism between LO and the reference oscillator is measured and stored in a Tuning Stabilizer memory circuit. This voltage is then applied to the reference oscillator to move it into synchronism with the LO. This is the offset compensation. Once the reference oscillator is in synchronism with the LO, switch A opens and switch B closes. The closing of switch B completes the operating stabilization loop. Error voltage is then applied to the YIG tickler coil to reduce the residual FM of the first LO. Through the use of offset compensation, the signal of interest remains on the CRT during initial stabilization.

ALTERNATE IF'S

The 8555A has a pair of frequency band scales which correspond to an alternate IF in the RF section. The IF is designated on the Frequency Band Scale drum. When these band scales appear in the window on the front panel of the 8555A, the shaft encoder on the band scale drum closes relays which bypass the 2050 MHz, making the first IF 550 MHz.

Why are alternate IF's necessary? Consider the following: What happens when a signal of 2050 MHz is applied to the input of the 8555A? Such a signal could pass directly through the first mixer with heterodyning. The baseline on the CRT would lift, preventing the analysis of the signal. To allow a signal near 2050 MHz to be analyzed, an alternate IF at 550 MHz is used.

SIGNAL IDENTIFIER

Chapter 2 of this manual developed the generalized tuning equation for harmonic mixing. It also explained image and multiple responses. Because of these responses it is necessary to provide some means for signal identification.

How does the signal identifier work? Consider the example in Figure 13. Three responses occur on the screen for a 5 GHz signal in the full scan mode. The fundamental, second, and third harmonic mixing products are all present. For the fundamental mixing product, the effective scan width in full scan is 2 GHz (LO scans from 2 to 4 GHz). For the second harmonic, the effective scan width in full scan is 4 GHz. (LO scans from 4 to 8 GHz.) Similarly, for the LO third harmonic the effective scan width is 6 GHz.

The signal identification scheme in the 8555A utilizes this difference in effective scan width.

To enable the signal identifier circuitry the SIGNAL IDENTIFIER switch must be ON and the SCAN WIDTH ≤ 1 MHz. A flip-flop is turned on. On alternate scans, this flip-flop shifts the third LO in frequency a preset amount equal to twice the setting of the scan width control. In this case let us assume that the scan width is in the 100 kHz/division position. The third LO then shifts a total of 200 kHz. The signals in the CRT will each shift 200 kHz. The direction of shift depends on the polarity of the mixing mode ("+" or "-"). To be able to discern which is the shifted signal, the gain in the 50 MHz amplifier is attenuated 6 dB during the shift.

How does shifting the third LO achieve signal identification? Let's assume the FREQUENCY BAND SCALE is set for the $n = 1-$ mixing mode. The $1/n$ attenuator, driven by the shaft encoder on the FREQUENCY BAND SCALE, calibrates the horizontal axis for 100 kHz/division for fundamental mixing. Hence, when signal shift occurs, the $1-$ response of the analyzer in Figure 13 moves 2 divisions or 200 kHz on the CRT. What about the other responses? The second harmonic response effective scan width is twice as great. For the second harmonic response, the horizontal scale calibration is effectively 200 kHz/division. Hence, when the second harmonic response shifts by 200 kHz, it only moves 1 division on the CRT. Similarly, the third harmonic only moves $\frac{2}{3}$ of a division on the CRT. The correct harmonic response on the CRT for a particular setting of the FREQUENCY BAND SCALE will move exactly 2 divisions. This is the signal identification test. The direction the signal moves indicates the polarity ("+" or "-") of the mixing mode, and this is important also in selecting the correct FREQUENCY BAND SCALE. For positive identification, the signal must shift to the left 2 divisions. The correct display is engraved on the front panel of the 8555A near the SIGNAL IDENTIFIER SWITCH. Signal identification, however, is not necessary with a tracking preselector. See Chapter 2.

8445B TRACKING PRESELECTOR

The tracking preselector is a narrow bandpass tracking filter. The preselector tracks a specific response of the analyzer. Consider again the generalized tuning equation:

$$F_s = nF_{1o} \pm F_{1f}$$

The tracking preselector tracks F_s for a given n , F_{1f} , and F_{1o} . The shaft encoder on the FREQUENCY BAND SCALE provides the information to determine n , F_{1f} , and

the correct sign, "+" or "-." The analog drive on the YIG main drive tuning coil provides the F_{10} information. Circuitry within the preselector solves the above equation and tunes the preselector to F_s . Note that the computation of F_s is completely AUTOMATIC and determined by the setting of the FREQUENCY BAND SCALE in the 8555A. Hence, the operator is free to concentrate on the measurement itself. Chapter 2 describes the improvement in performance of the analyzer through the use of a preselector.

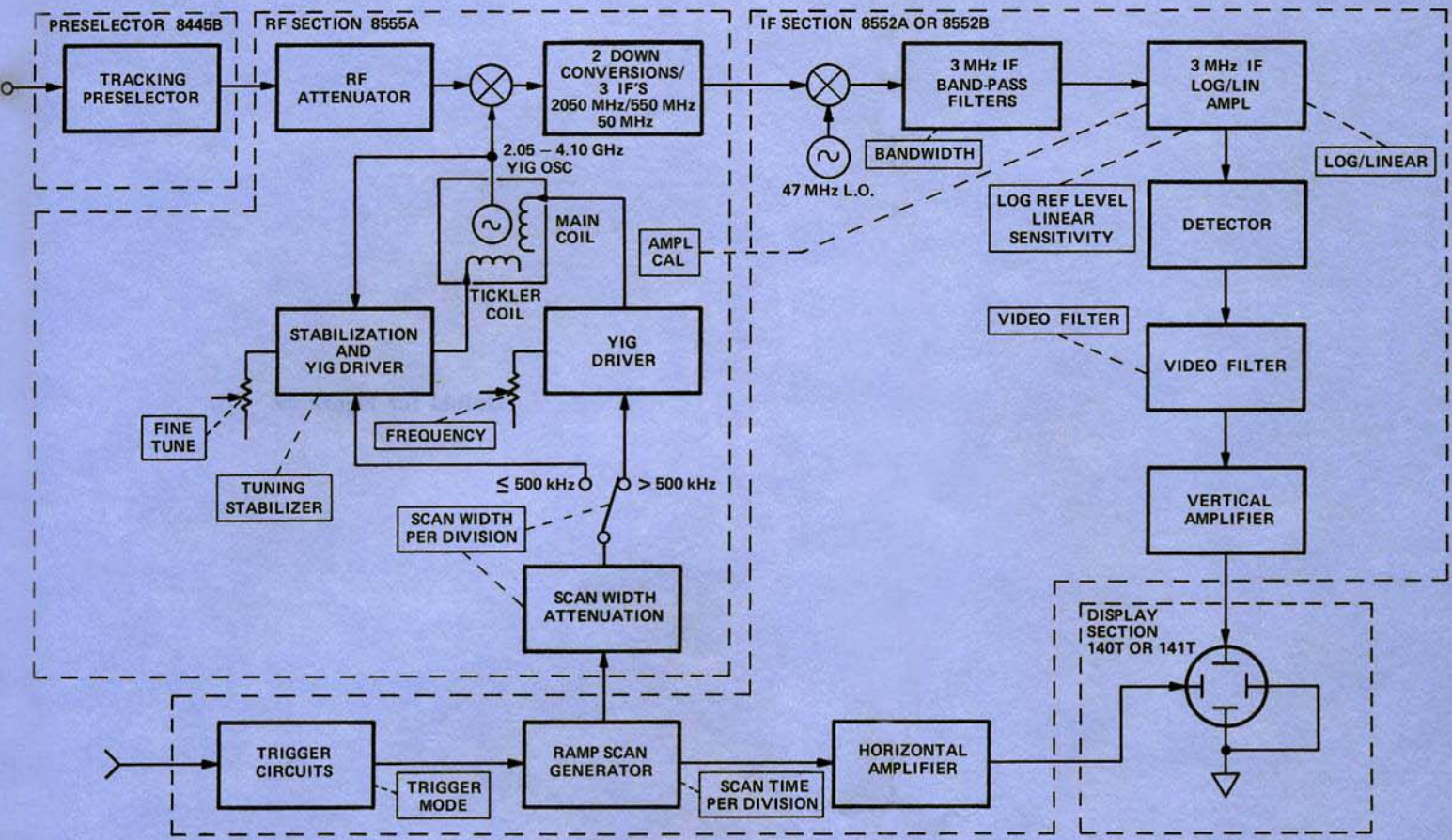

Figure 39. 8555A Spectrum Analyzer System.

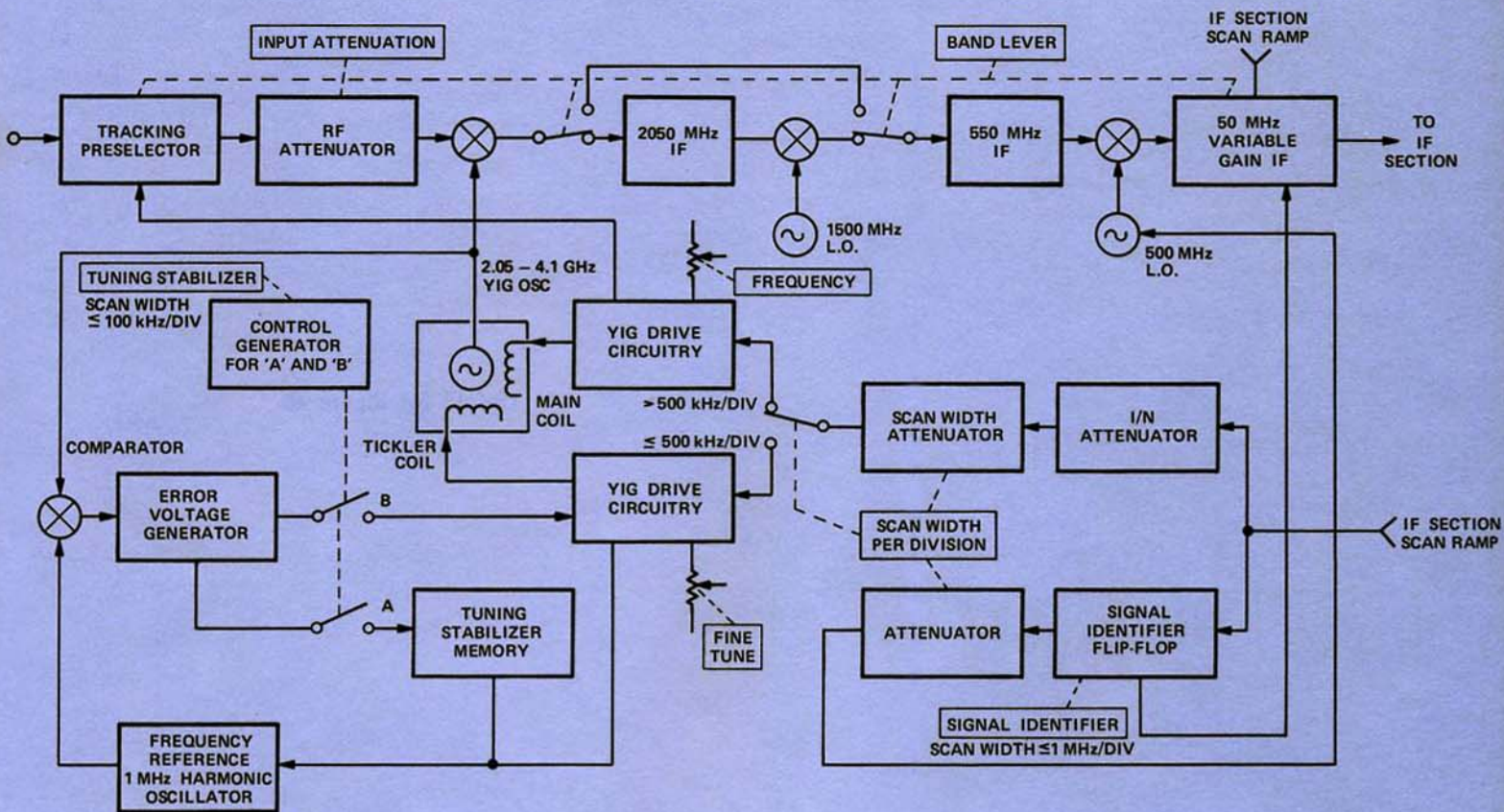

Figure 40. 8555A RF Section and Preselector.

